

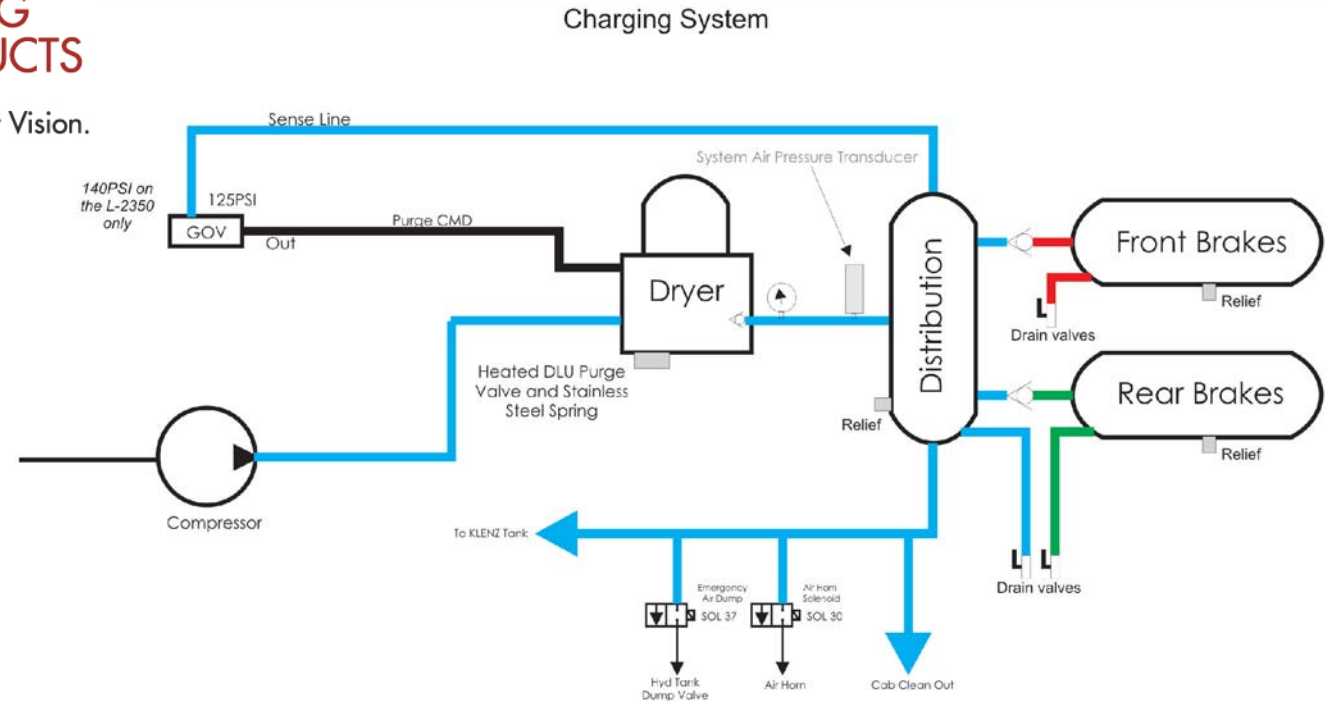

LeTourneau
TECHNOLOGIES™

MINING
PRODUCTS

Built On Experience. Driven By Vision.



Compressed Air Systems

COMPRESSED AIR SYSTEM

LeTourneau Technologies, Inc.



COMPRESSED AIR SYSTEM

- Theory of Operation
- Component Descriptions
- Circuit Descriptions
- Settings and Adjustments
- Troubleshooting
- Removal and Installation



THEORY OF OPERATION



L-1350 / L-1850 / L-2350 AIR SYSTEM

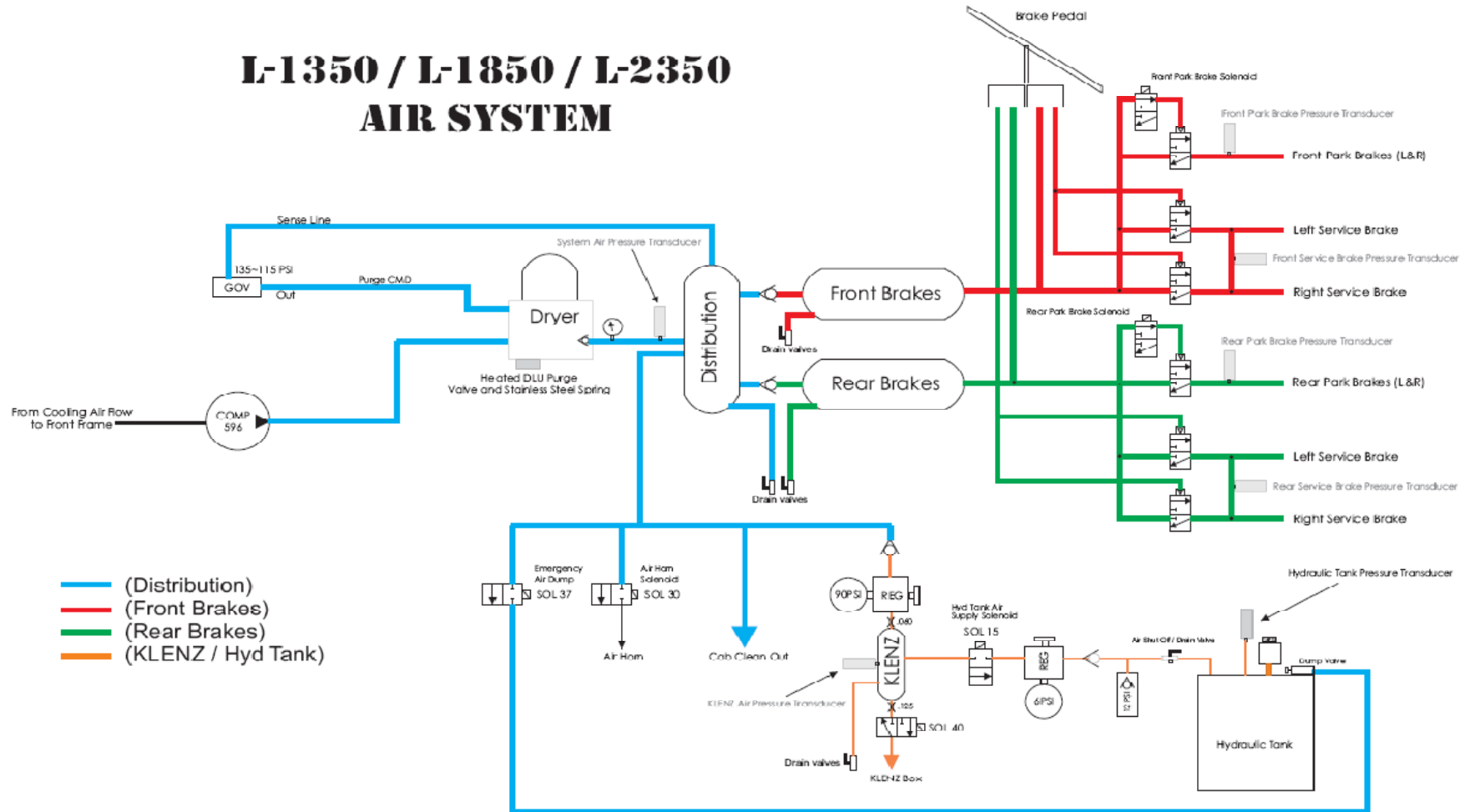

COMPONENT DESCRIPTIONS



COMPONENT DESCRIPTIONS

- Compressors
- Valves
- Tanks
- Solenoids
- Transducers



Model	Displacement (CFM) at 1250 RPM	Displacement (CFM) at 1900 RPM (120psi)	Displacement (CFM) at 1900 RPM (140psi)	Allowable inlet Temp °f	Allowable outlet Temp. °f	Boosted CFM at 1900RPM (120psi)	Lubrication	Cooling
750	16.5	11.7	10	250	400	34	Engine oil	Coolant
596	27	23	19.7	250	400	NA	PTO	Hyd Oil
922	31.7	27.8	23.8	170	350	NA	PTO	Coolant



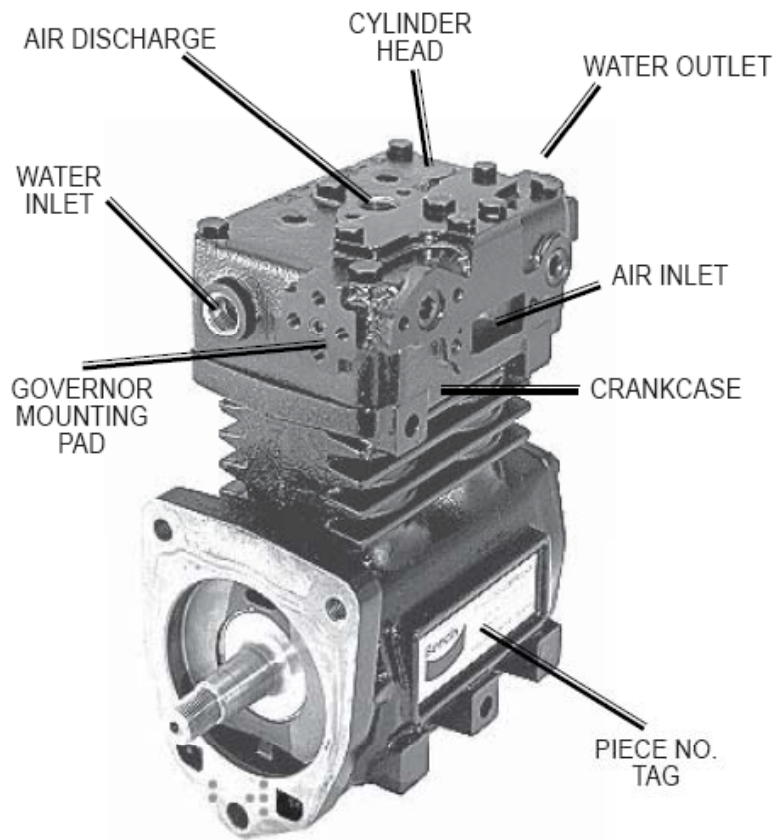

BENDIX® TU-FLO® 750 AIR COMPRESSOR
(EXTERIOR)

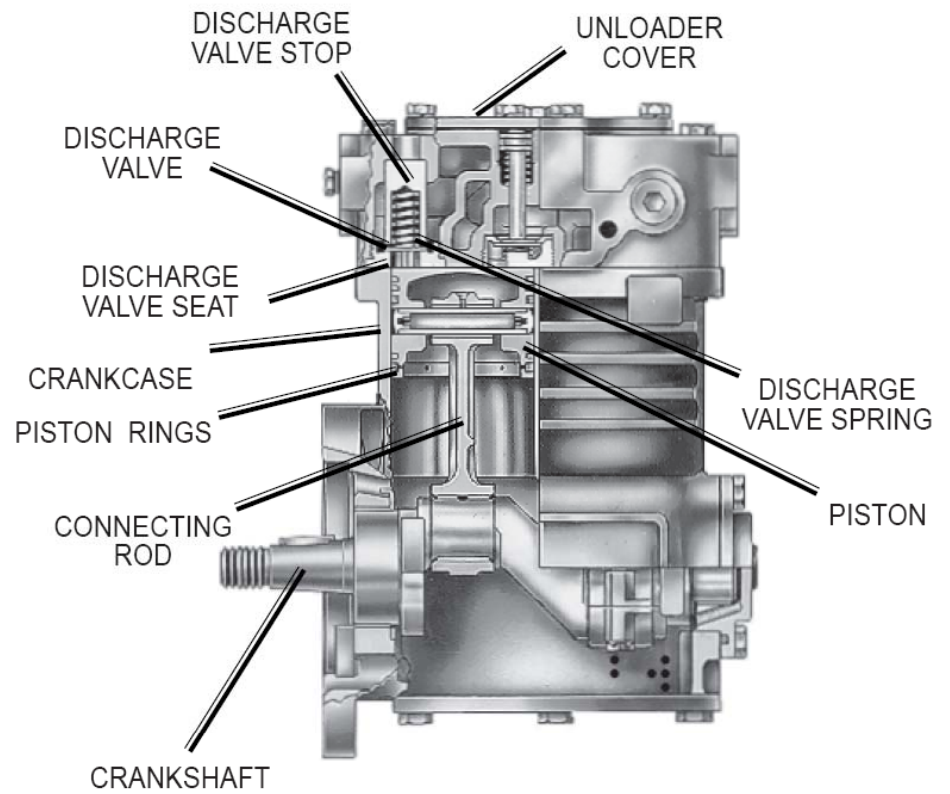

BENDIX® TU-FLO® 750 AIR COMPRESSOR
(CROSS SECTION)

BENDIX TU-FLO 750 COMPRESSOR



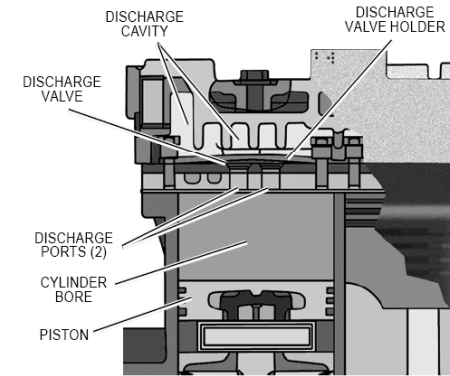
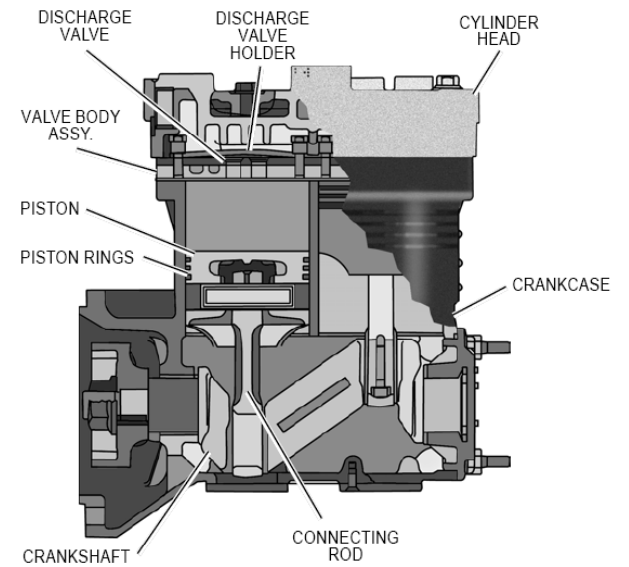
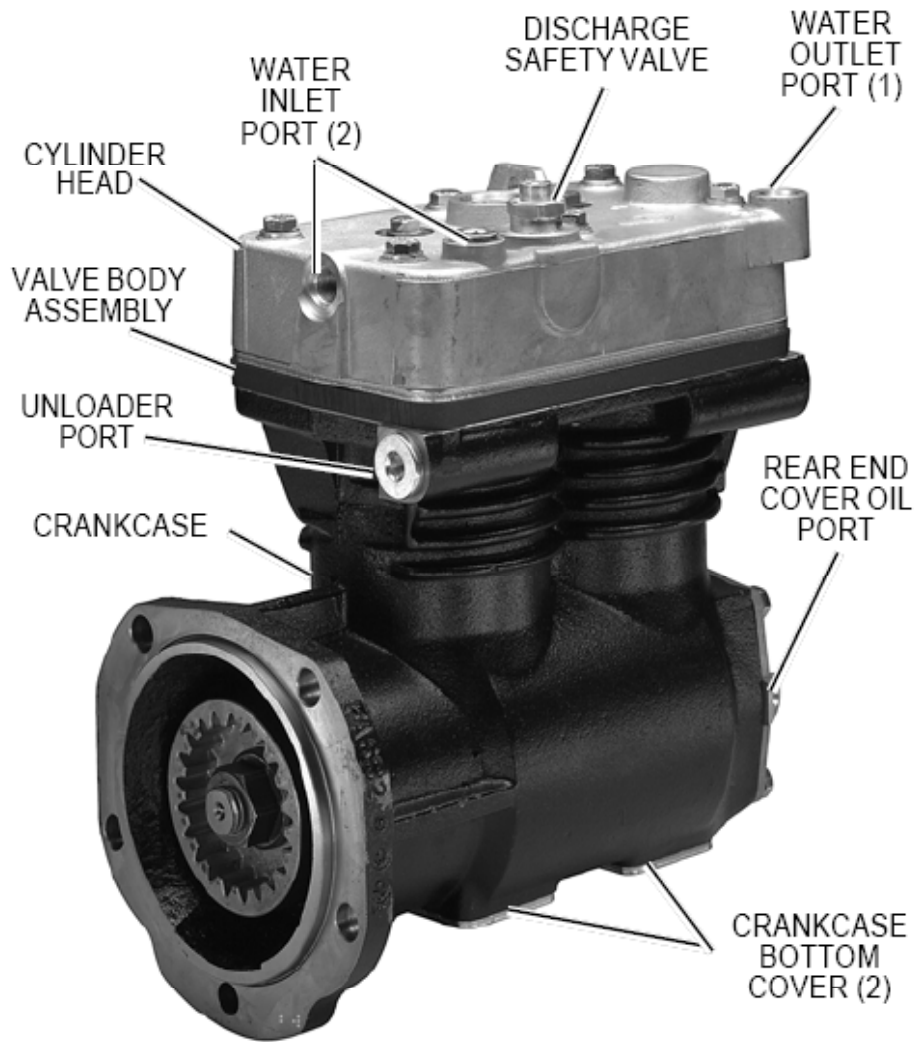

VIEW OF CYLINDER HEAD AND ONE CYLINDER BORE

BENDIX DURAFLO 596 COMPRESSOR



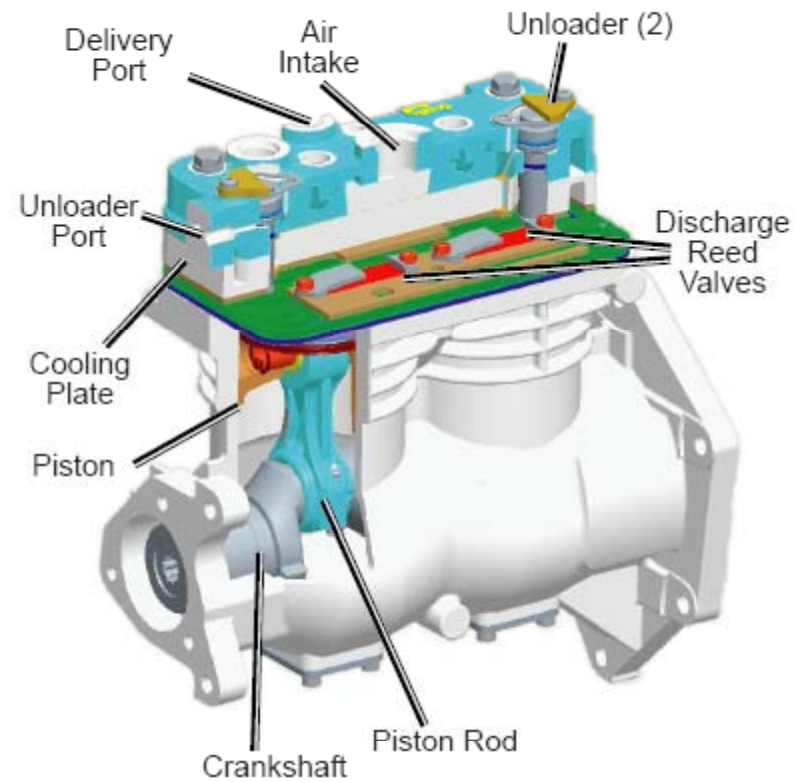
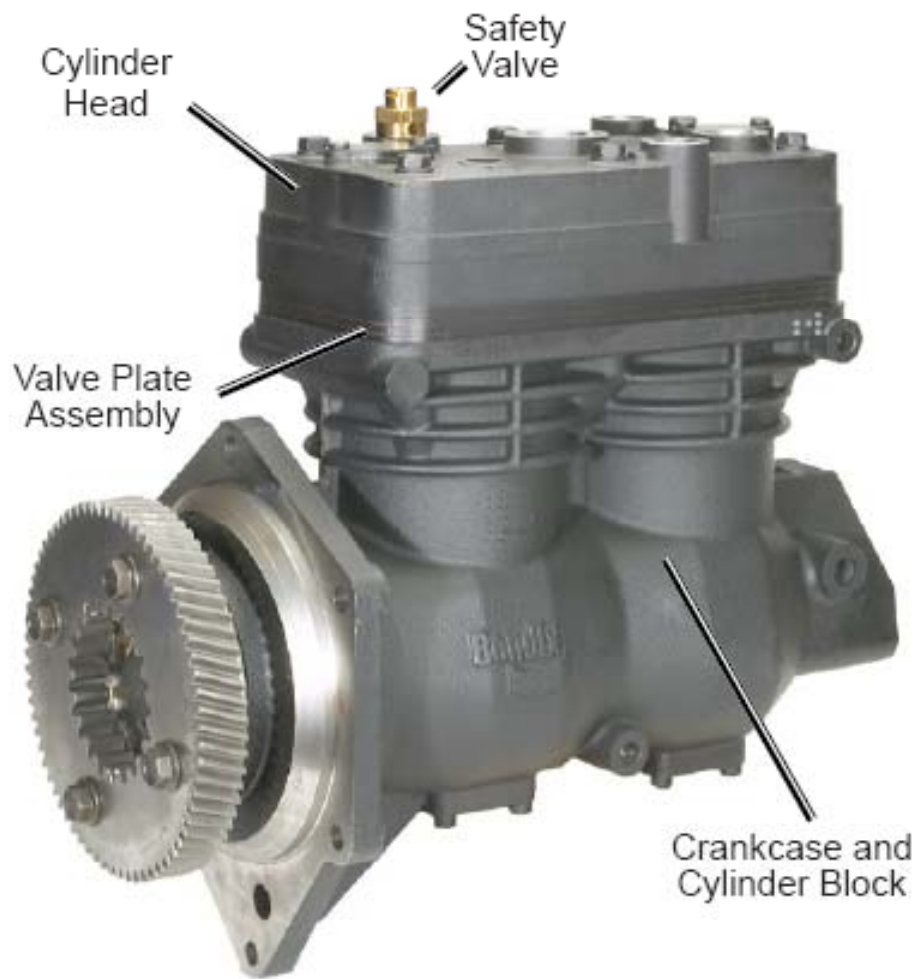

BENDIX BA-922 COMPRESSOR





Engine Mounted TU-FLO 750 on L950's

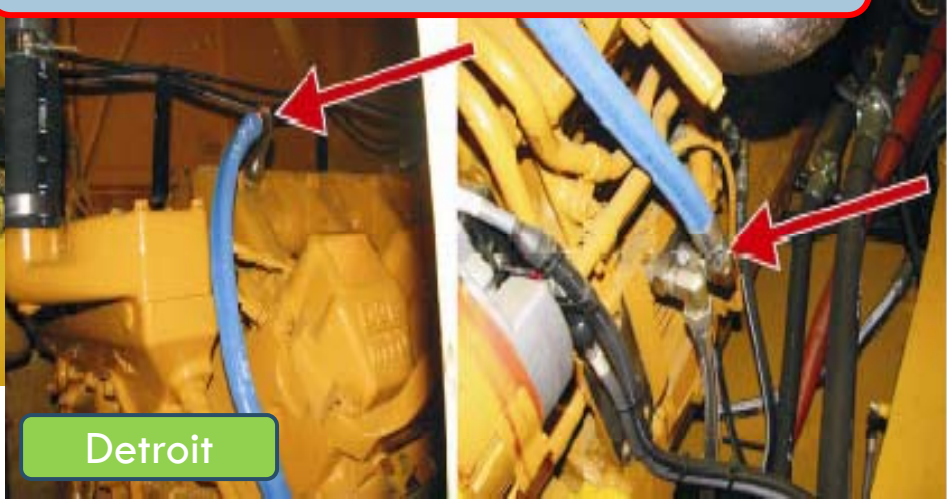

L1350, L1850, & L2350

COMPRESSOR INLET

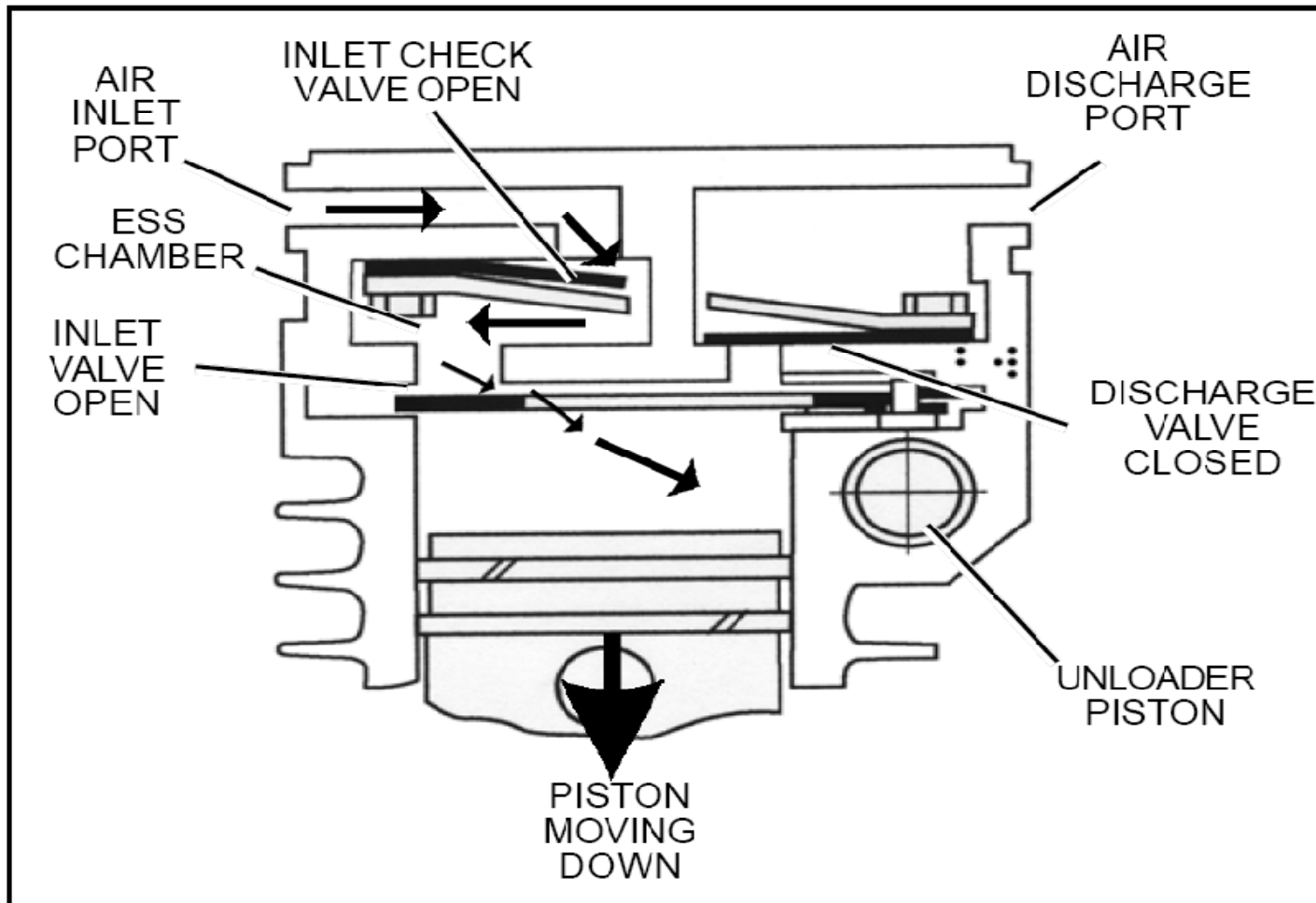

COMPRESSOR CYCLE - INTAKE



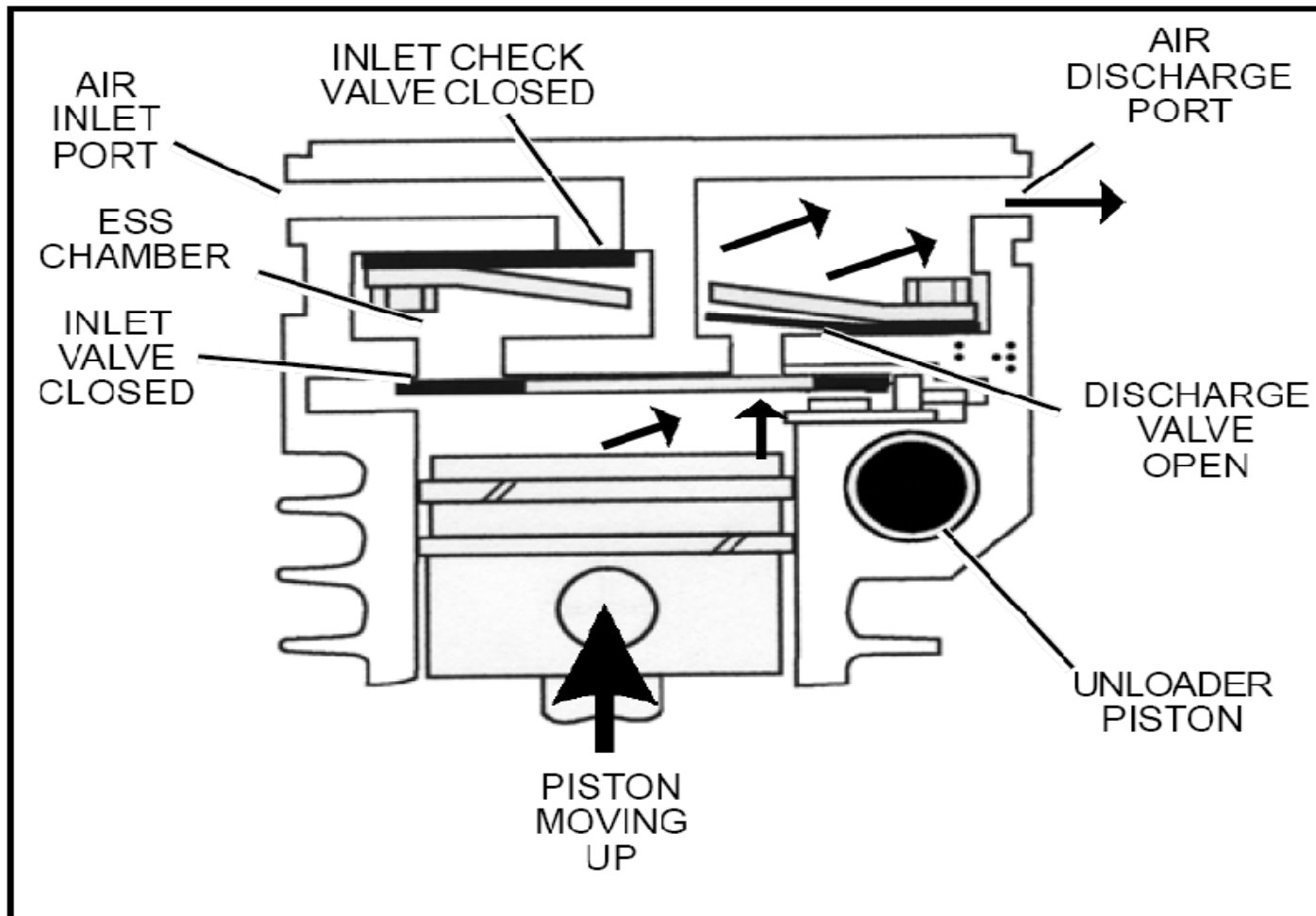

COMPRESSOR CYCLE - COMPRESSION

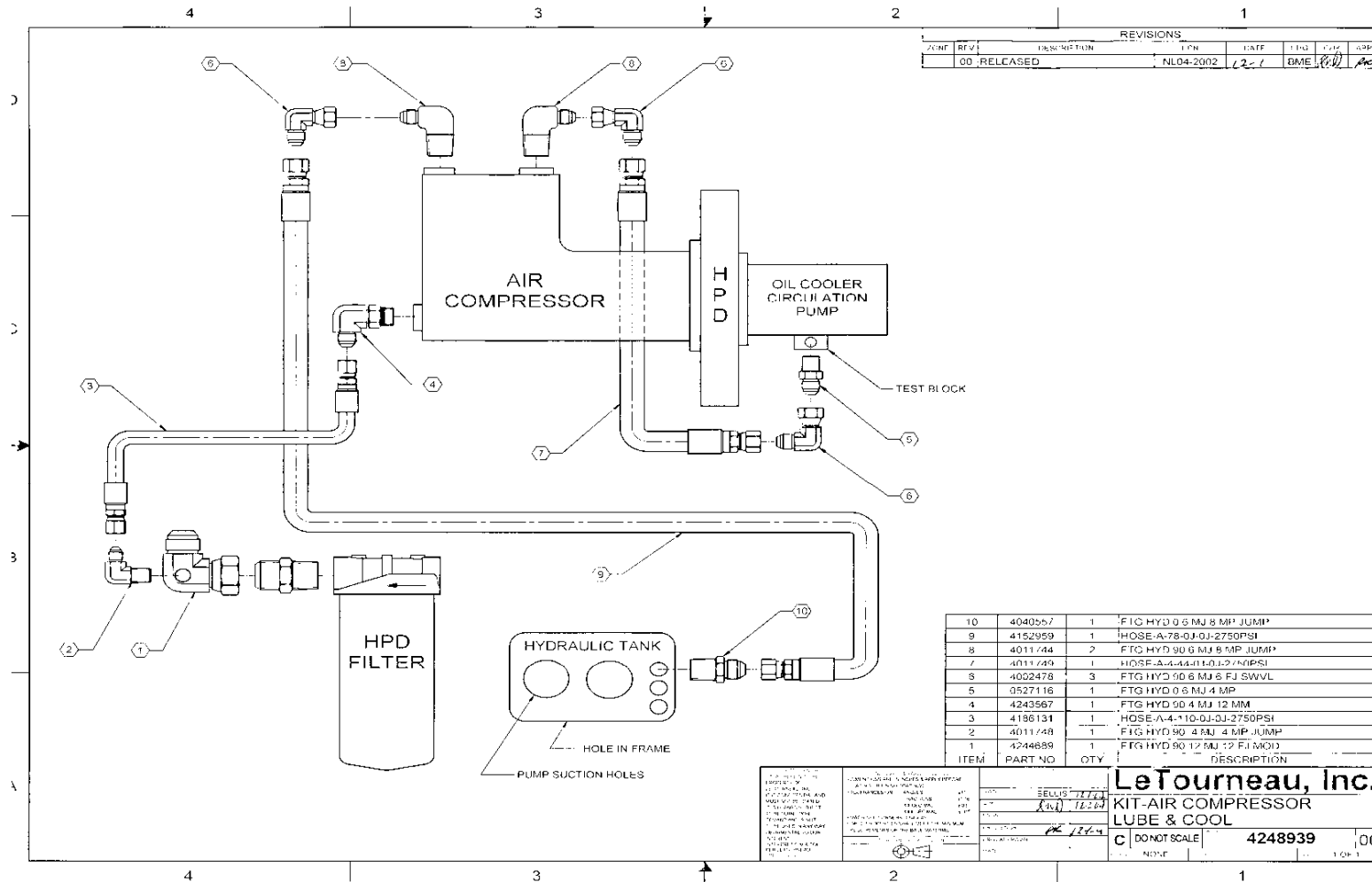

COMPRESSOR COOLING AND LUBE

Component Descriptions

LeTourneau Technologies, Inc.

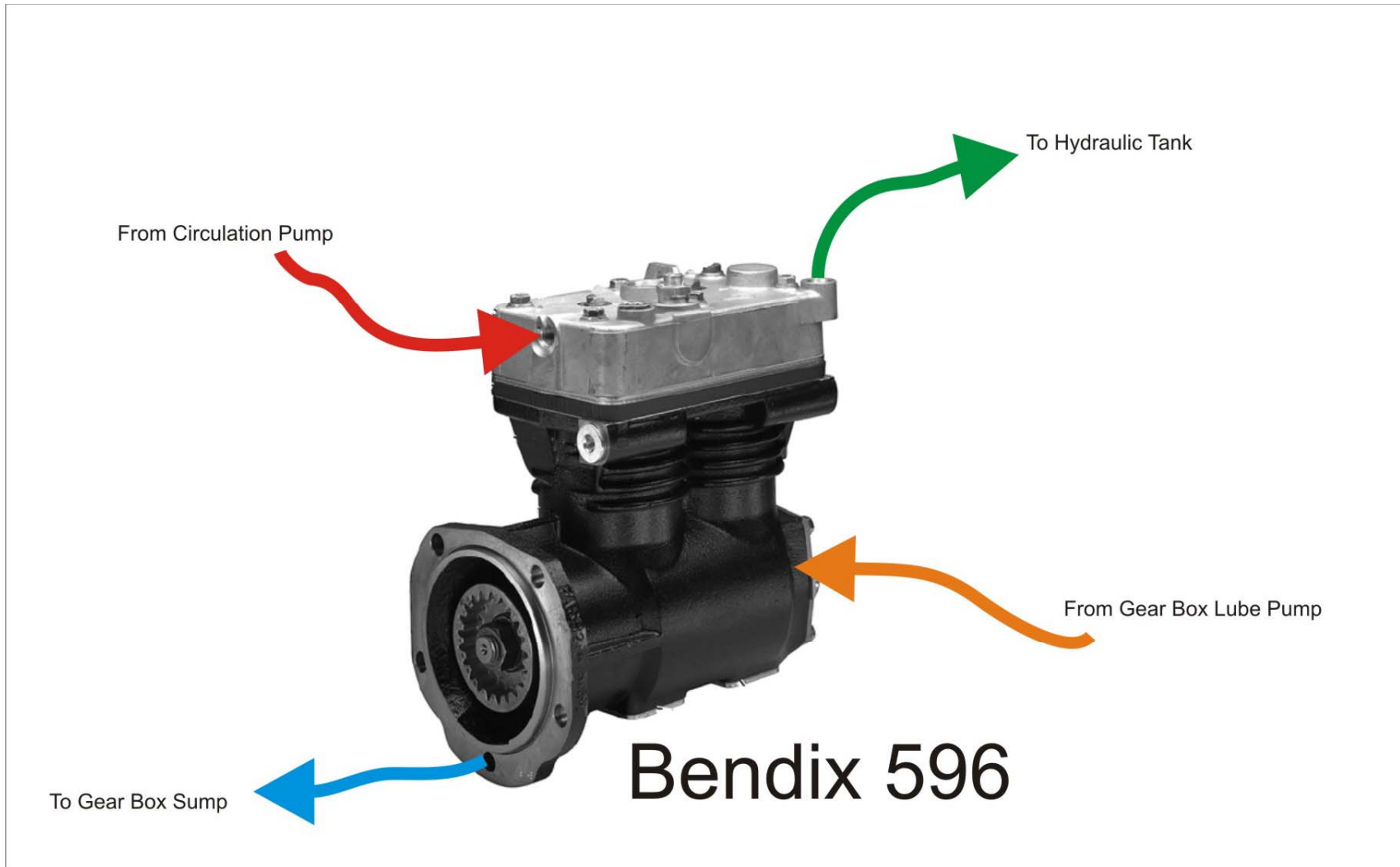

596 COMPRESSOR COOLING LUBE CIRCUIT



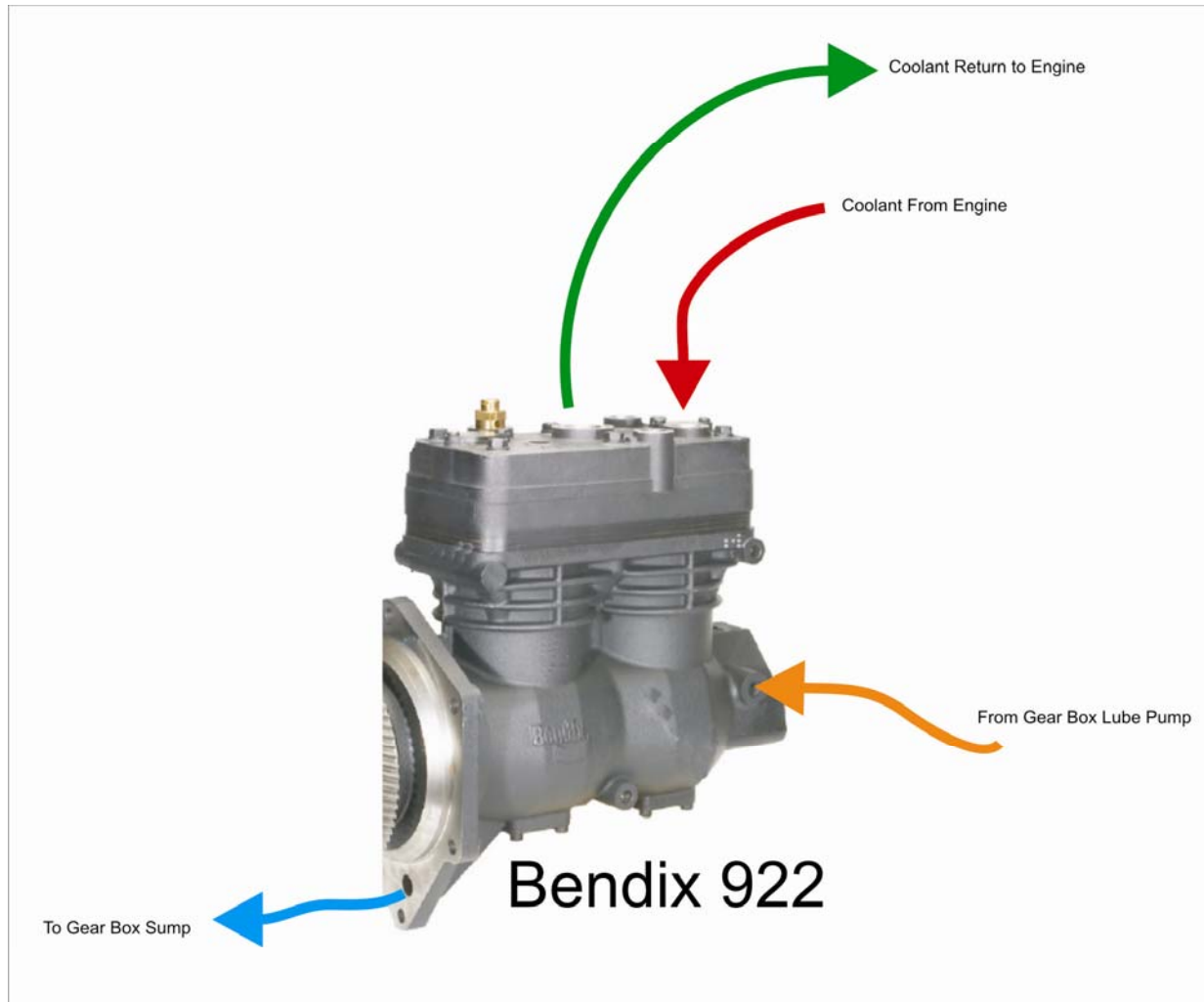

922 COMPRESSOR COOLING LUBE CIRCUIT



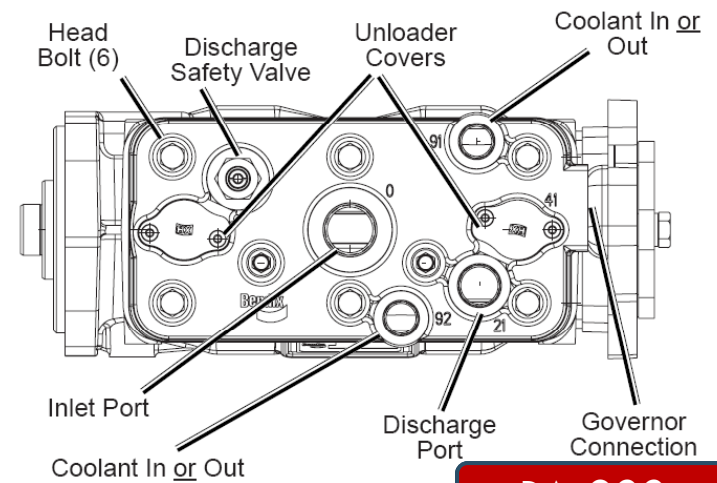
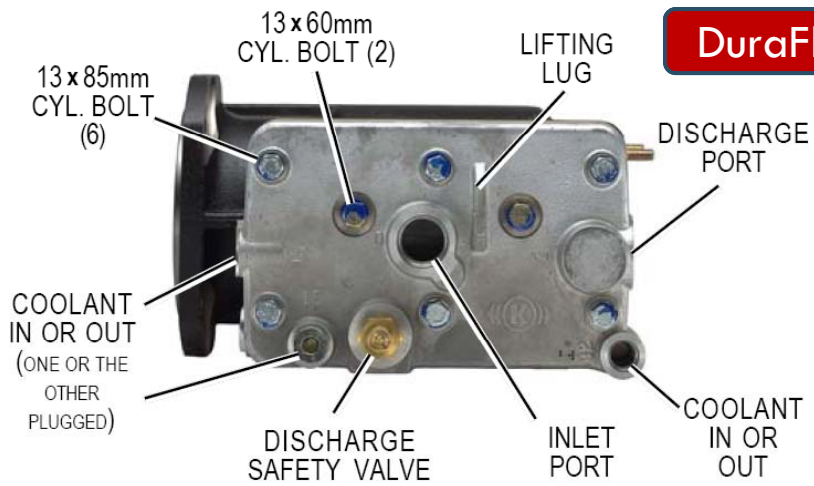

TU-Flo 750

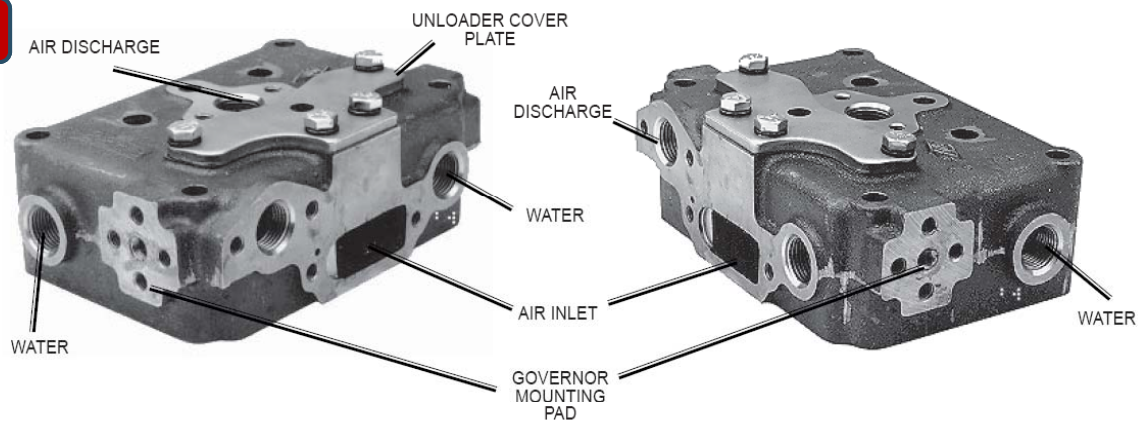

COMPRESSOR PORTING DESCRIPTION

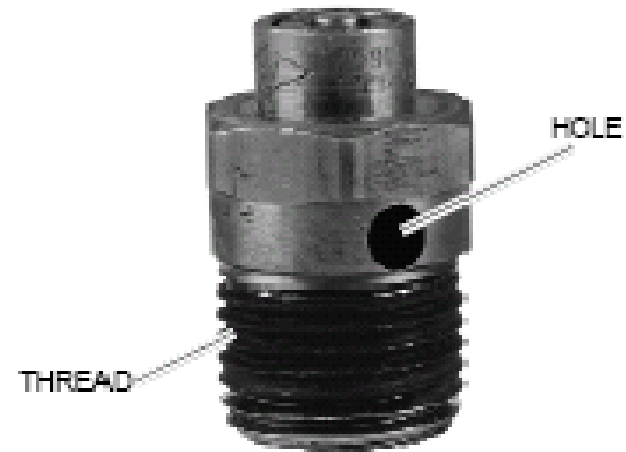

COMPRESSOR 250 PSI SAFETY RELIEF

Component Descriptions

LeTourneau Technologies, Inc.

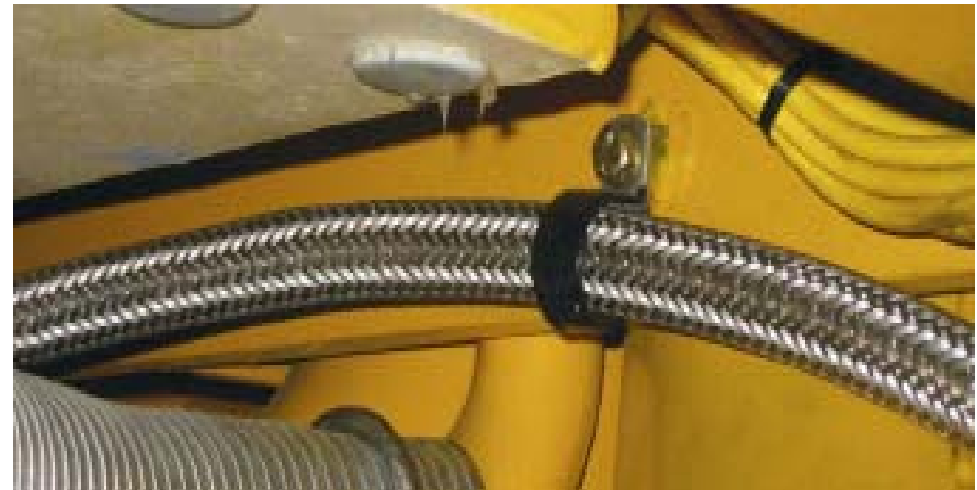

COMPRESSOR OUTLET
STAINLESS STEEL 120 INCH HOSE

Component Descriptions

LeTourneau Technologies, Inc.

- 200 PSI Safety Relief
- 24 VDC Heater and Thermostat
- Desiccant Cartridge
- DLU Purge Valve
- Outlet Check Valve

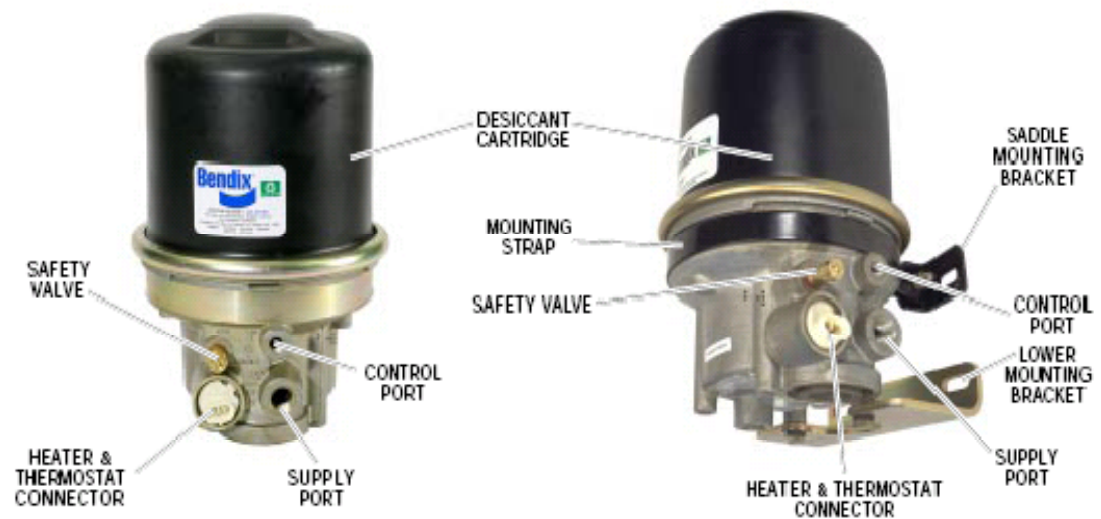

AD-IP Bendix Air Dryer Description

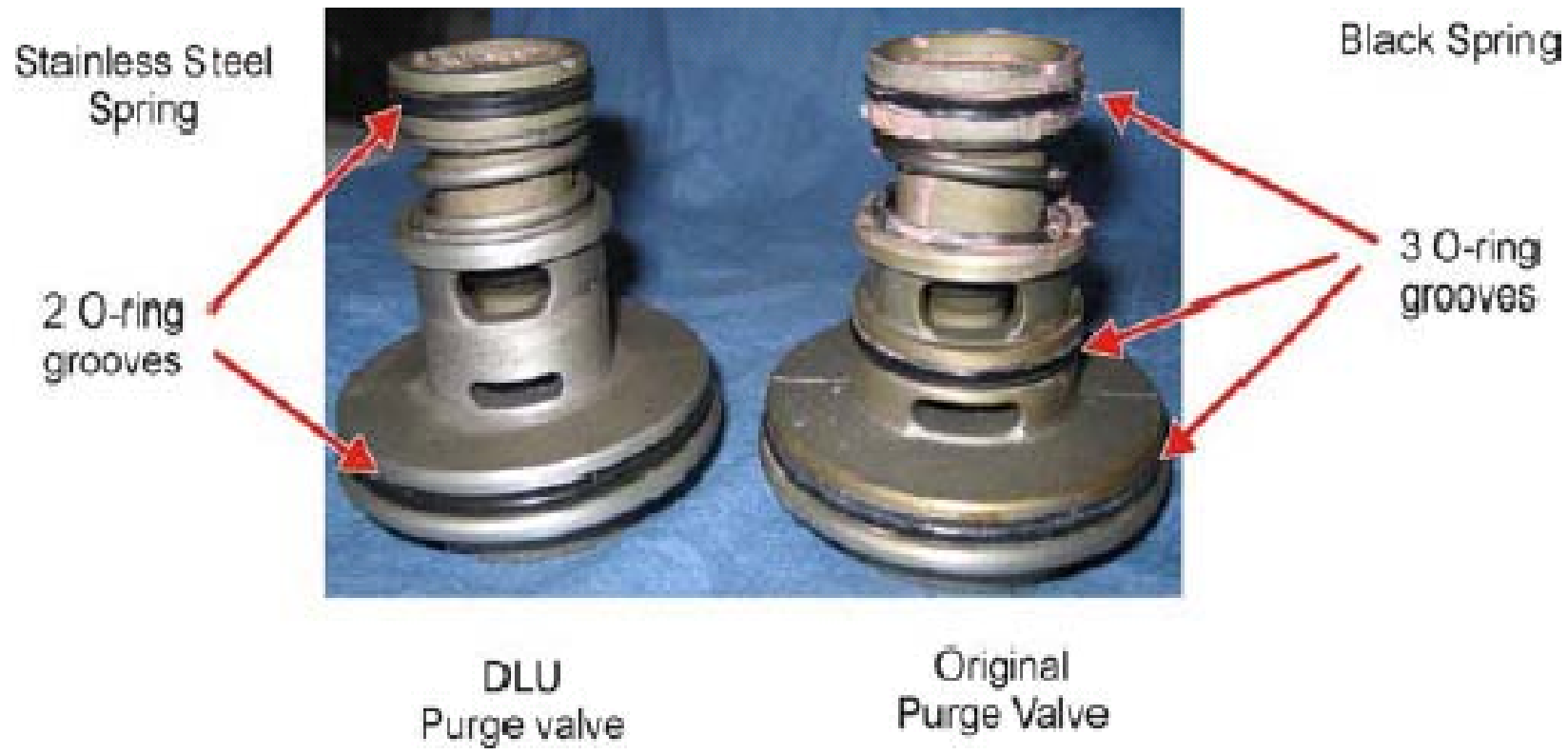

Purge valve comparison

AIR DRYER DLU [DISCHARGE LINE UNLOADER]

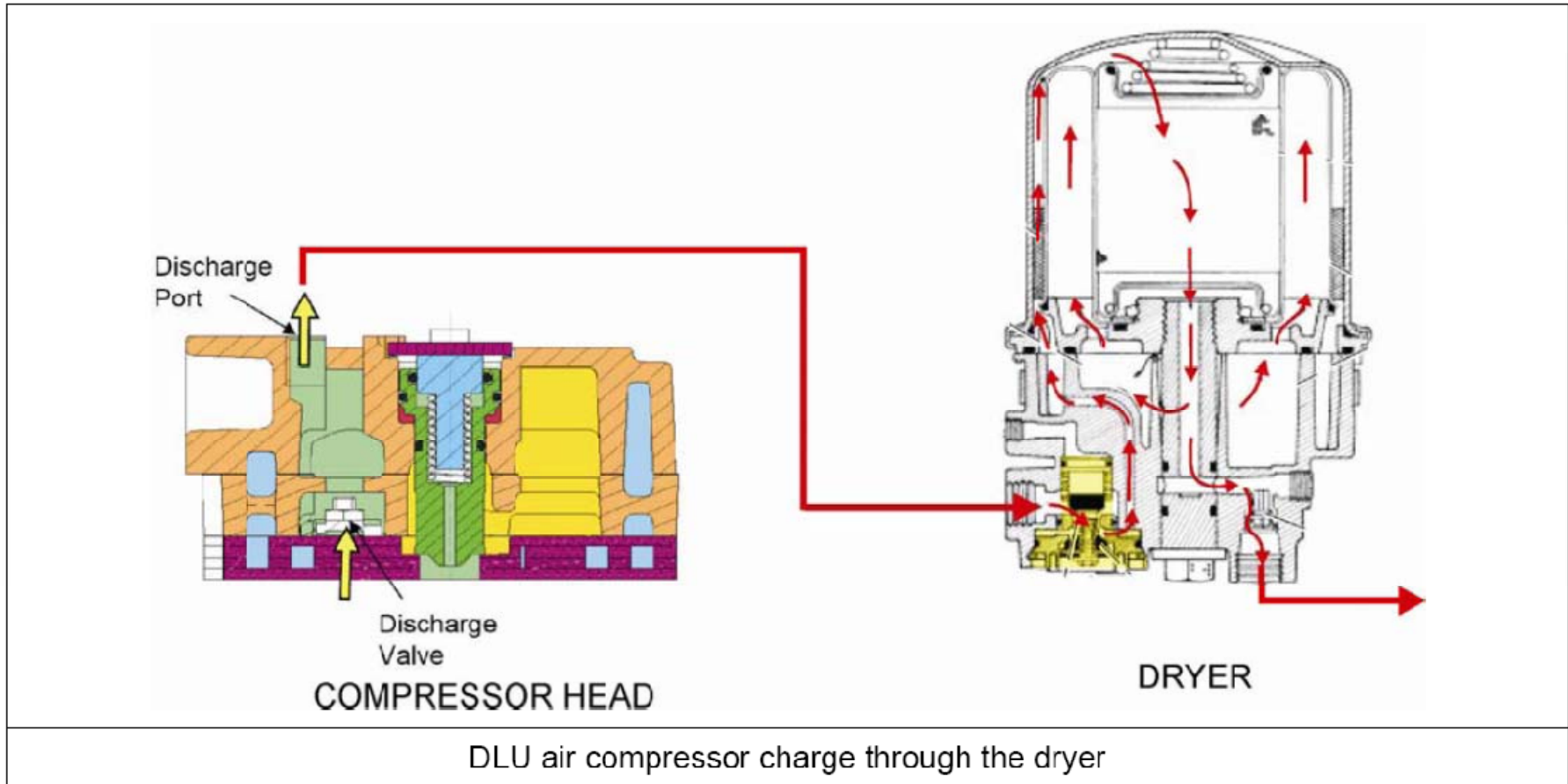

Dryer Operation Cycle - System Charging

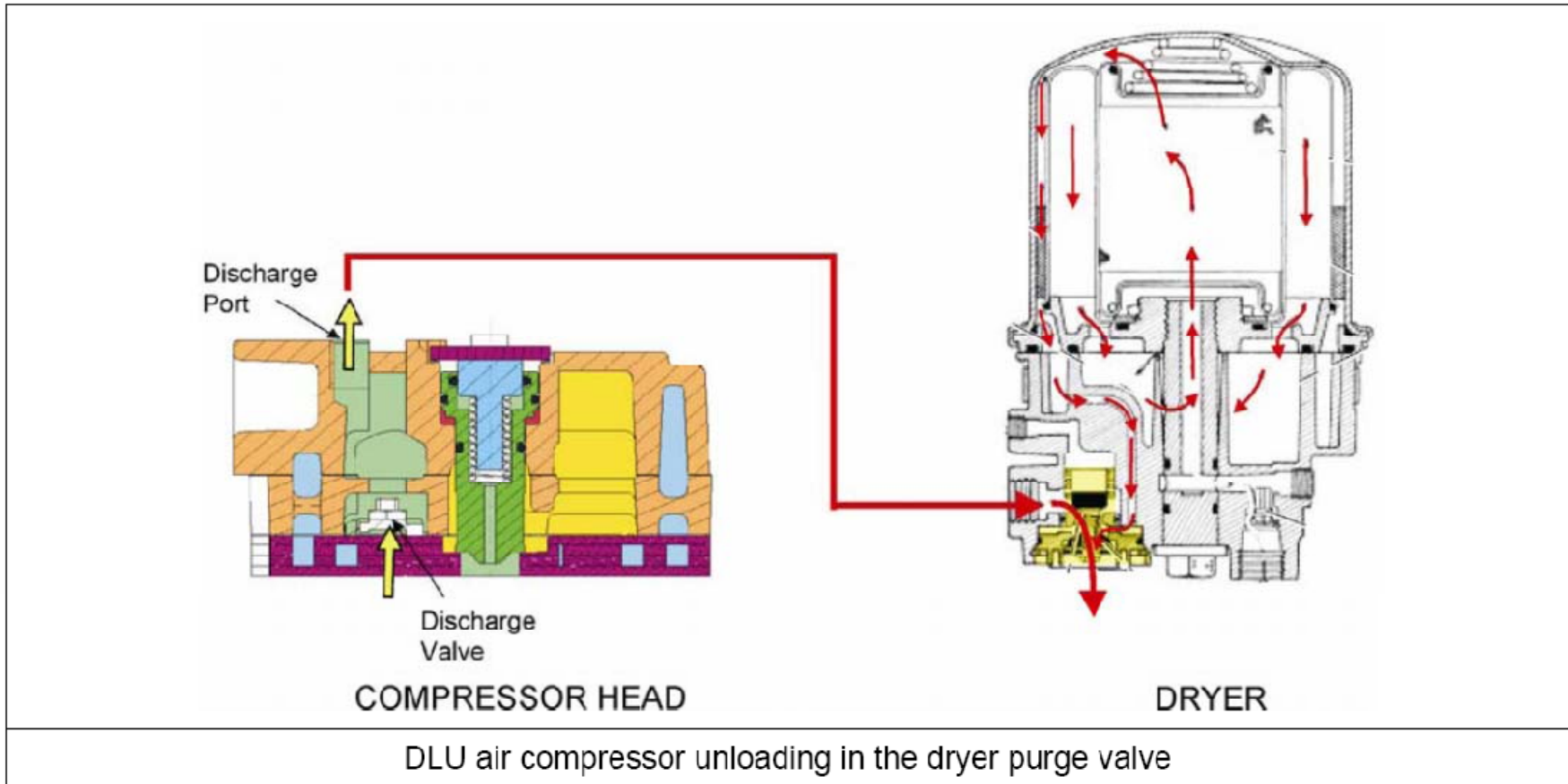

Dryer Operation Cycle – System Unloading and Purge

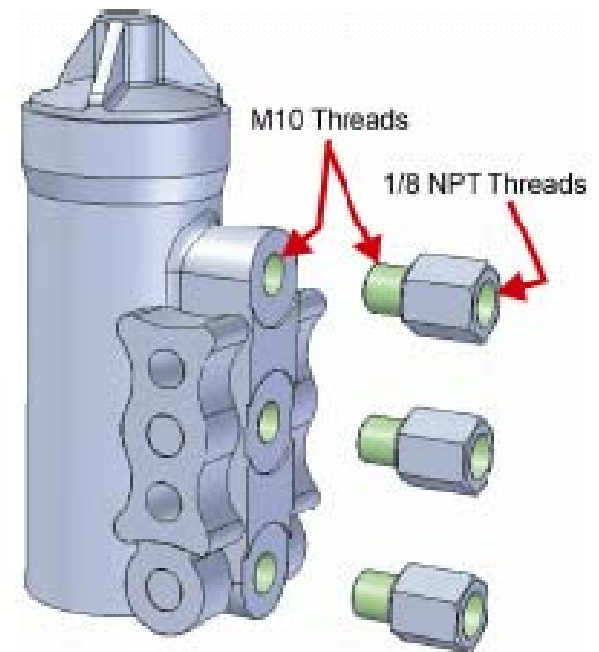
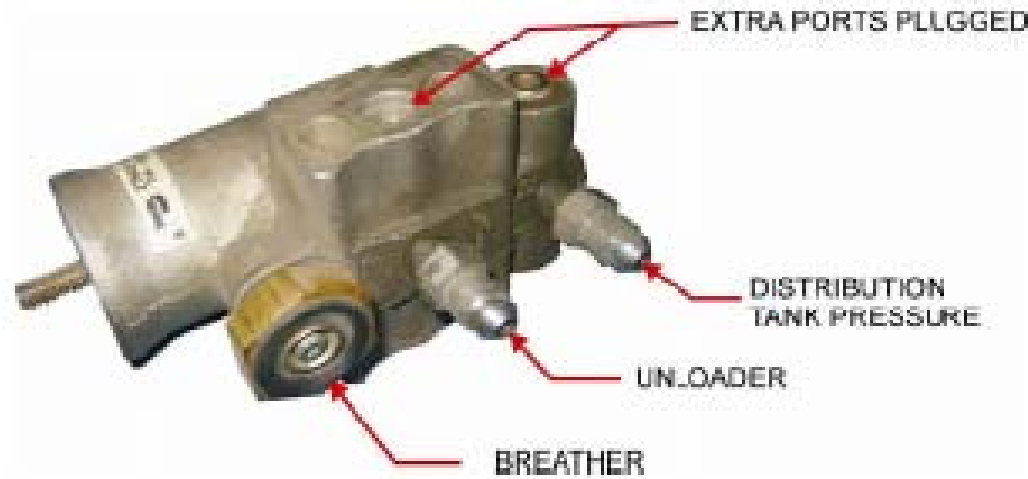

Governor Description

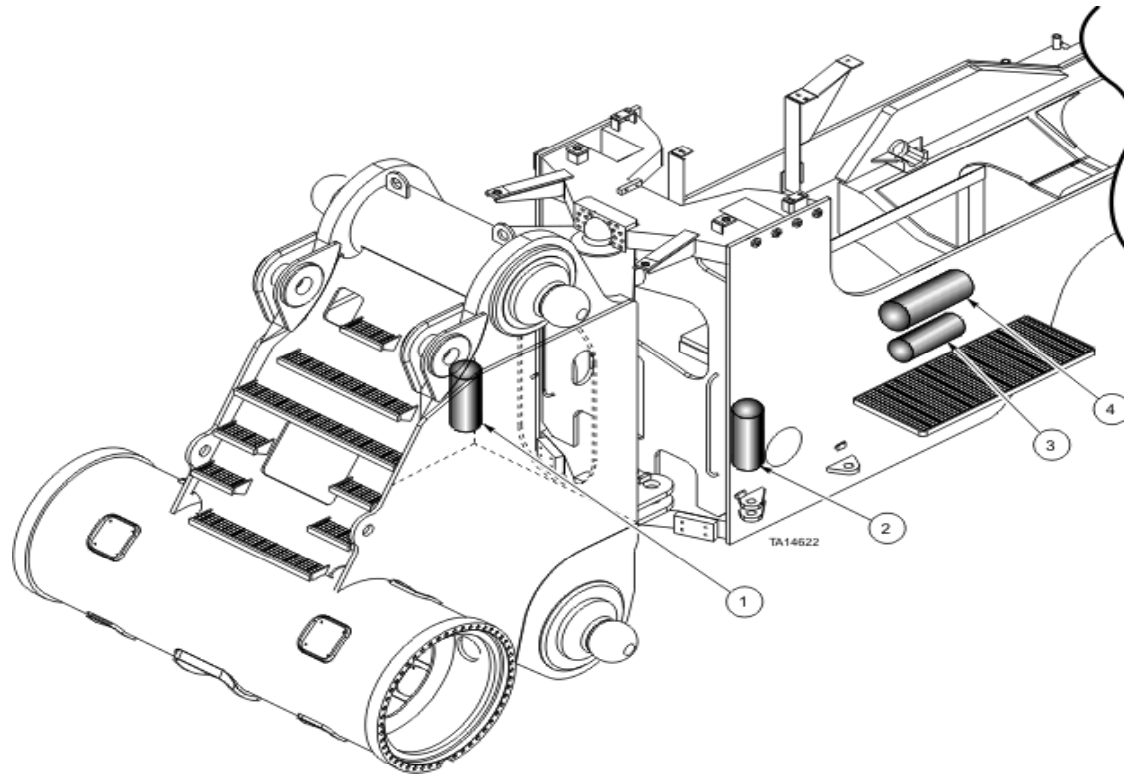

1. Front Brakes
2. Main Receiver
3. KLENZ
4. Rear Brakes

950 [Except KLENZ] = 1791 cu.in.

1350-1850-2350 [Except KLENZ] = 2146 cu.in.

KLENZ = 557 cu.in.

Distribution Tanks - General Location

Check Valve

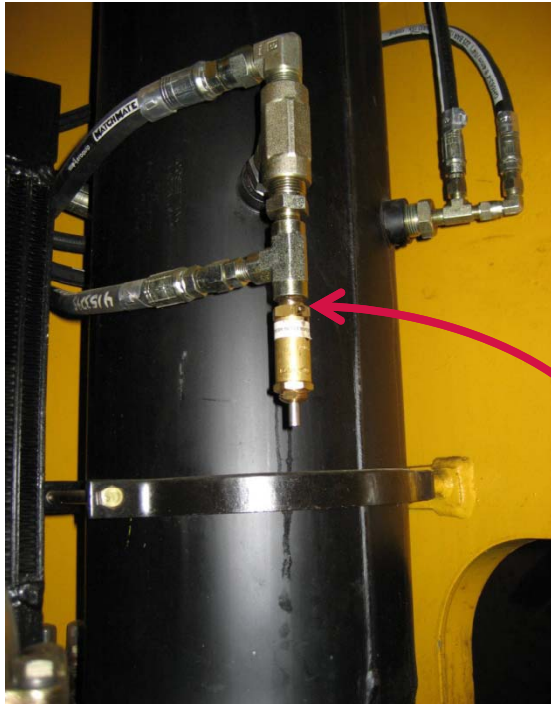

175 psi Safety Valve

DISTRIBUTION TANKS VALVES

Distribution Tank Drain Valve

Gauge

Transducer

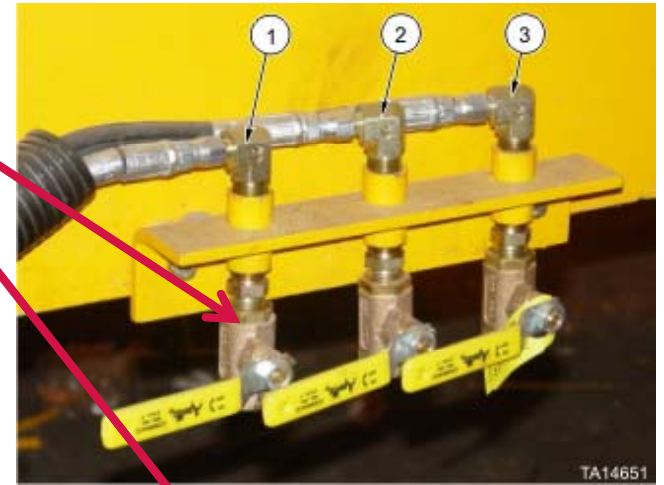
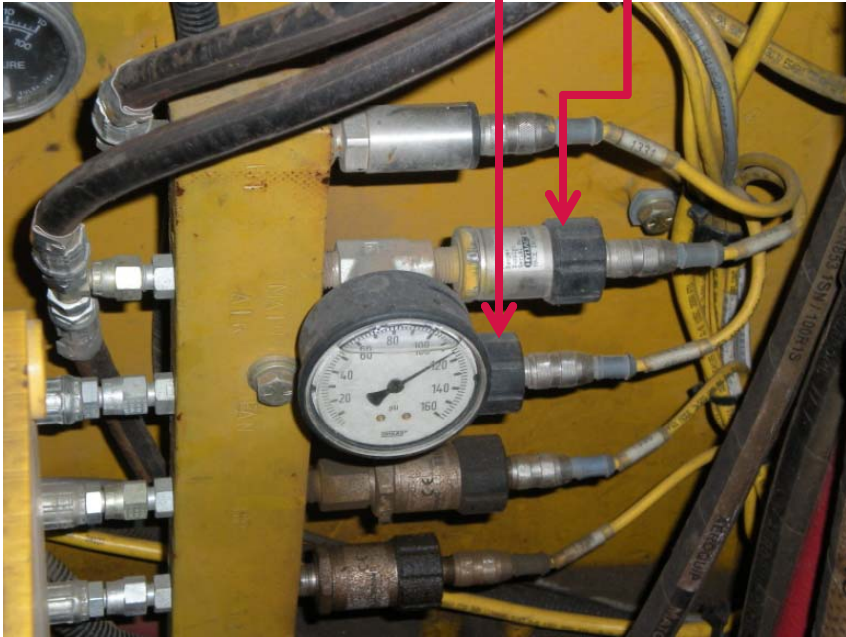



Air Horn Solenoid 30

Cab Cleanout



AUXILIARY FUNCTIONS - AIR HORN AND CAB CLEANOUT

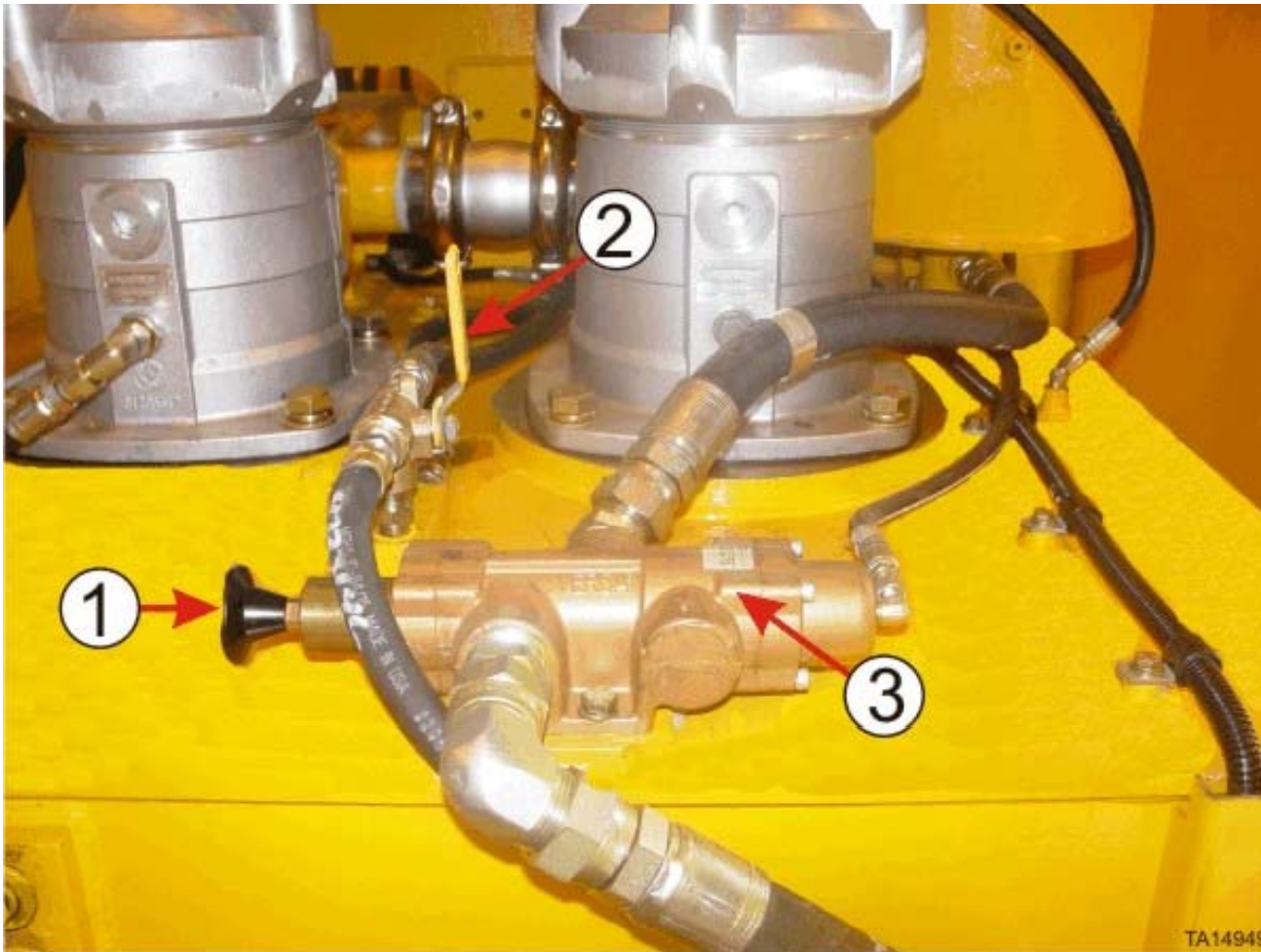

1. Shuttle Valve Actuator
2. Manual Valve
3. Valve Body

AUXILIARY FUNCTIONS - DUMP VALVE SOLENOID 37

- Brake Pedal
- Park Brake Solenoid (Front Solenoid # 34 Rear Solenoid # 35)
- Brake Relay Valve
- Brake Actuator
- Pressure Transducer

Air System Brake Components



BRAKE PEDAL

Component Descriptions

LeTourneau Technologies, Inc.

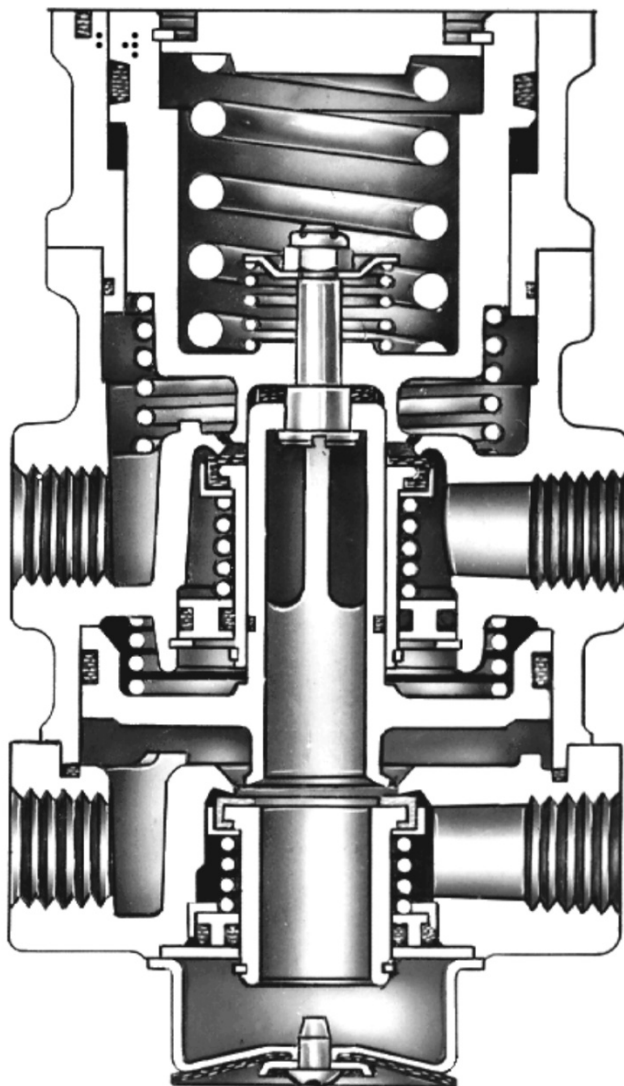

TREADLE VALVE

Component Descriptions

LeTourneau Technologies, Inc.

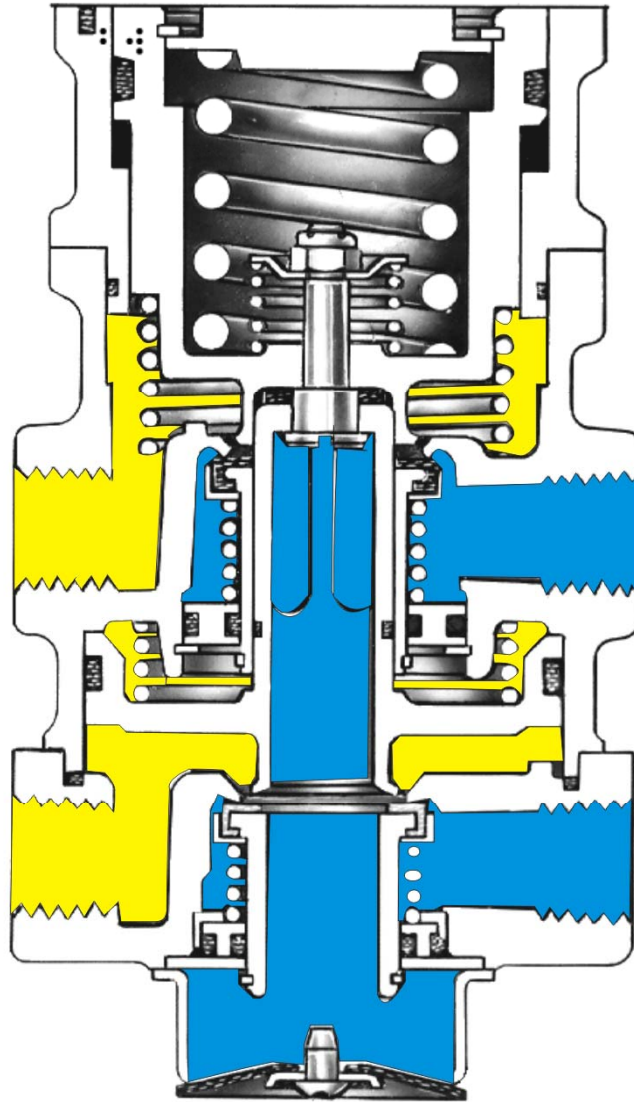

TREADLE VALVE

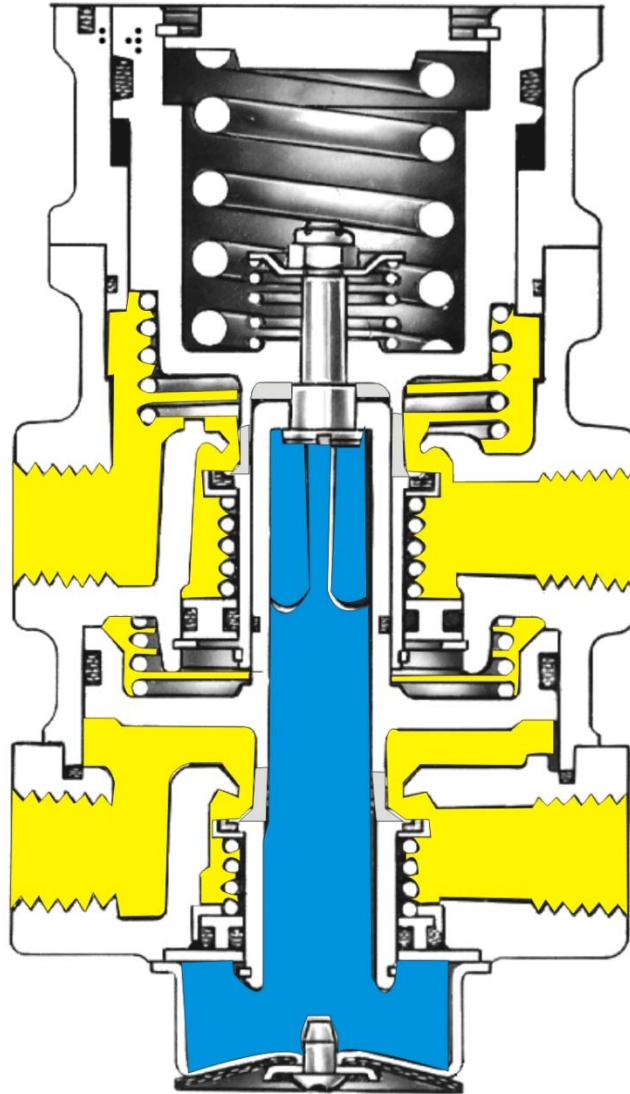

TREADLE VALVE

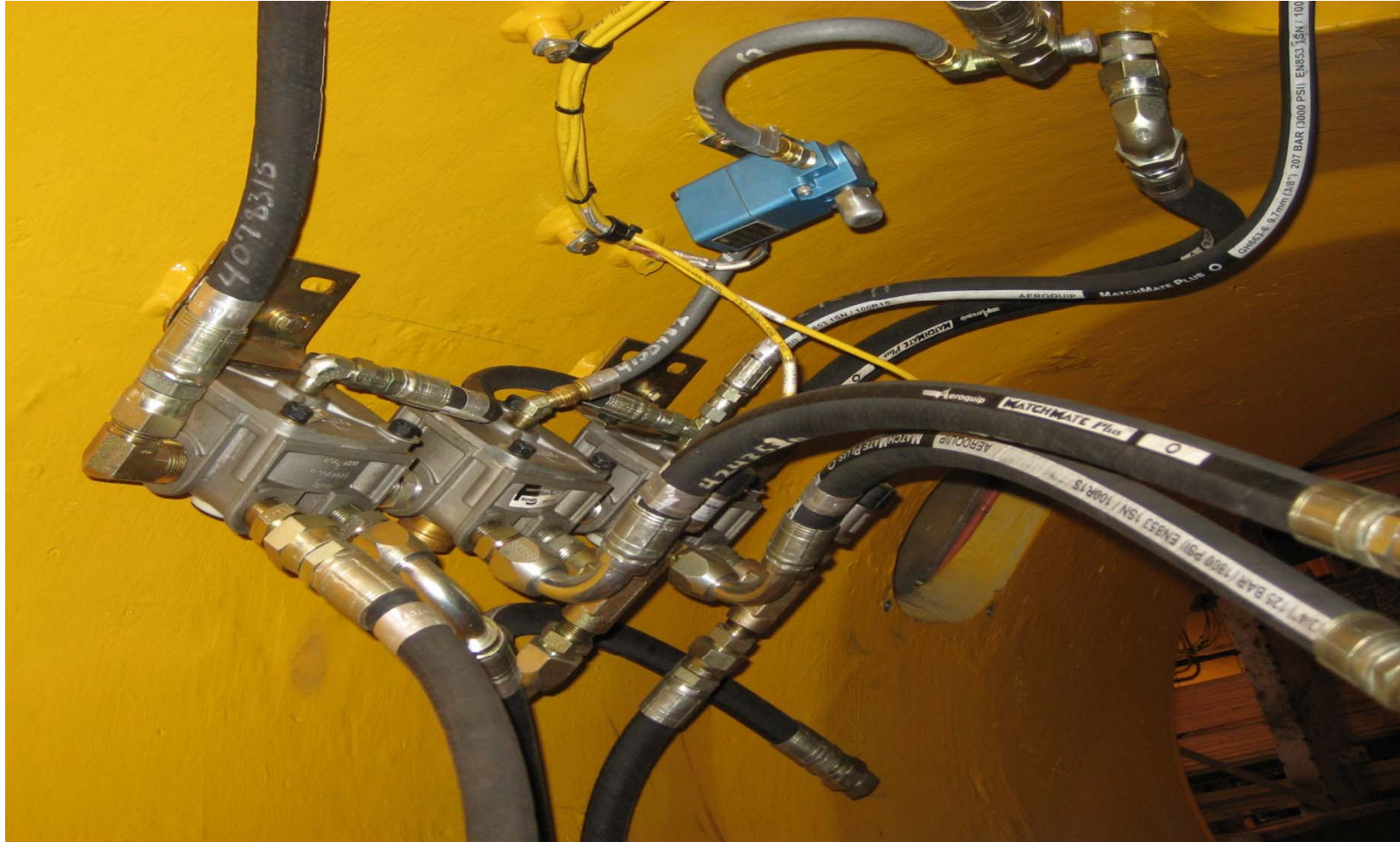

BRAKE RELAY VALVES

Component Descriptions

LeTourneau Technologies, Inc.

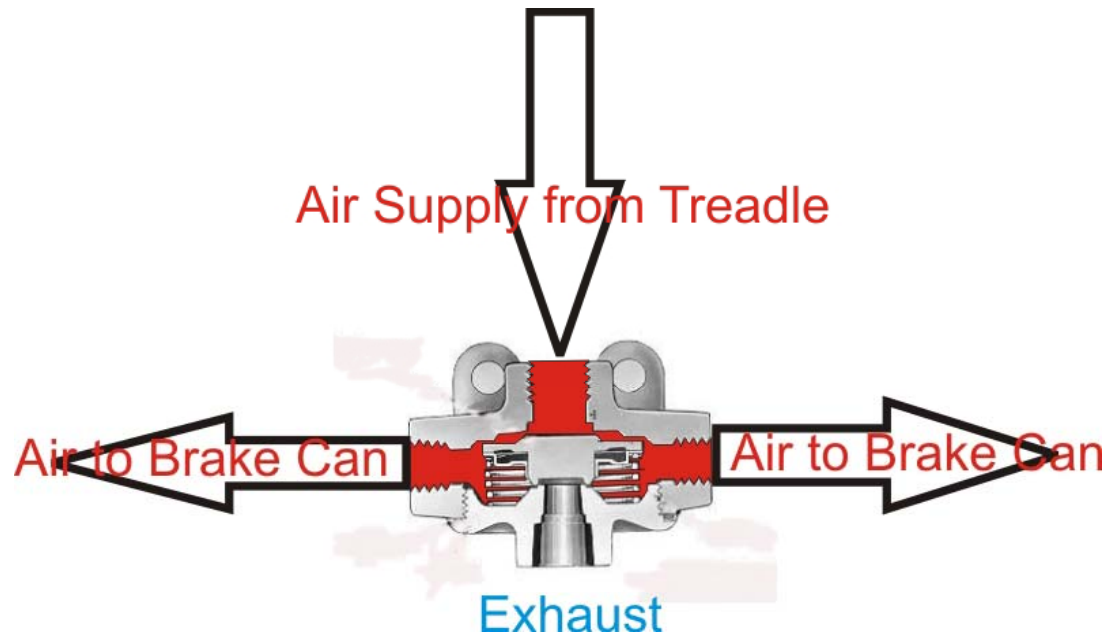

Brake Treadle Supply



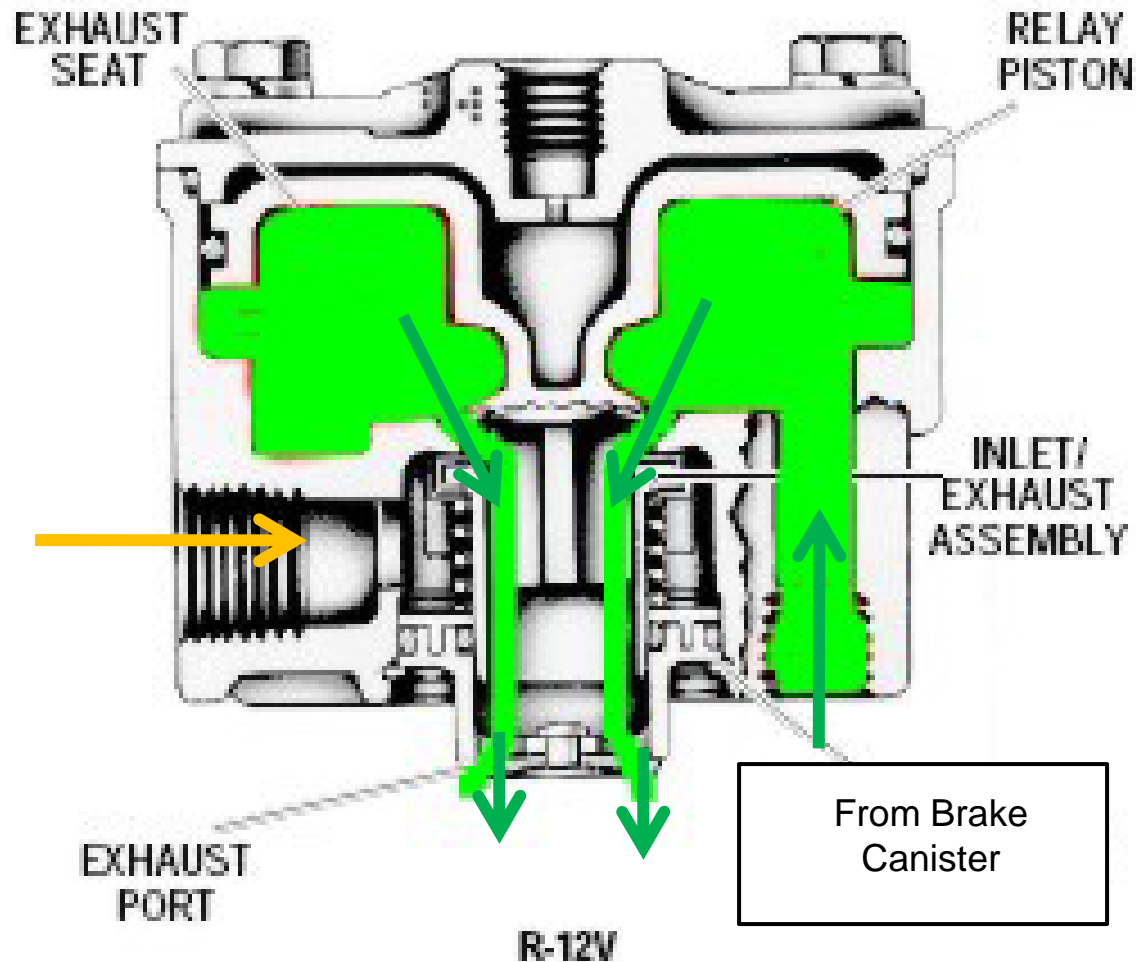

Brake Relay Valve - Not Actuated

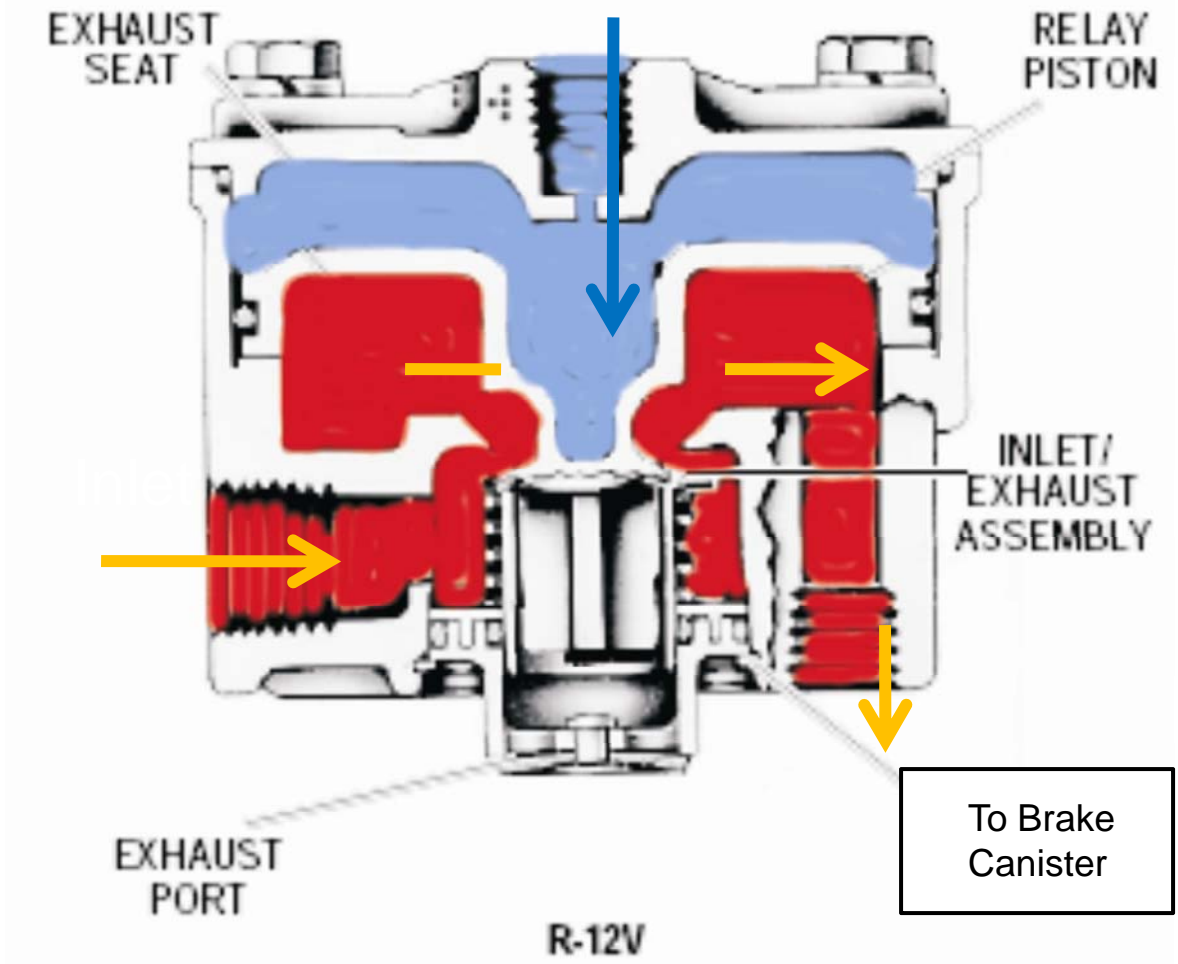

Brake Relay Valve - Actuated

L-950 QUICK REACTION VALVE

QRV™ Quick Release Valve

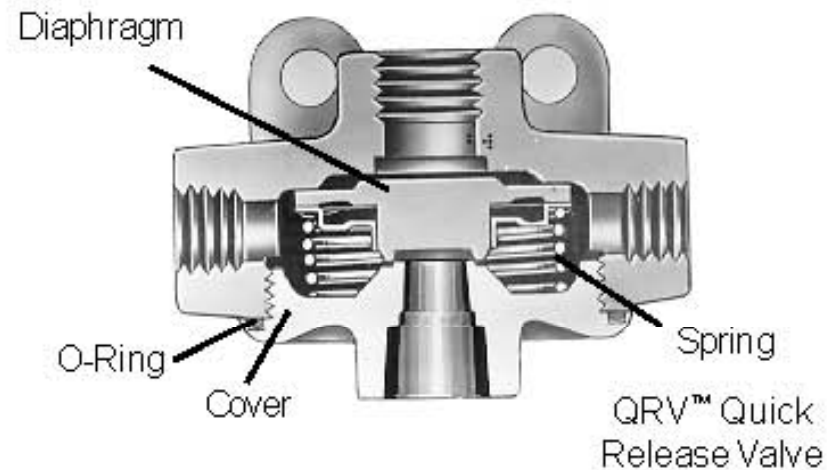
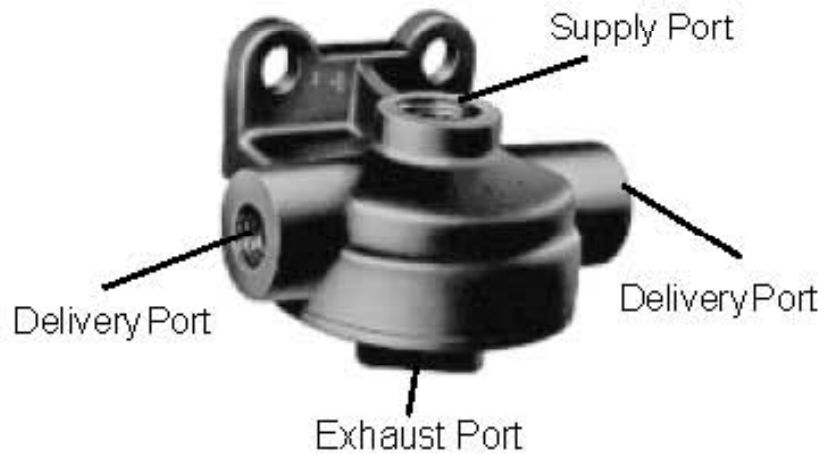

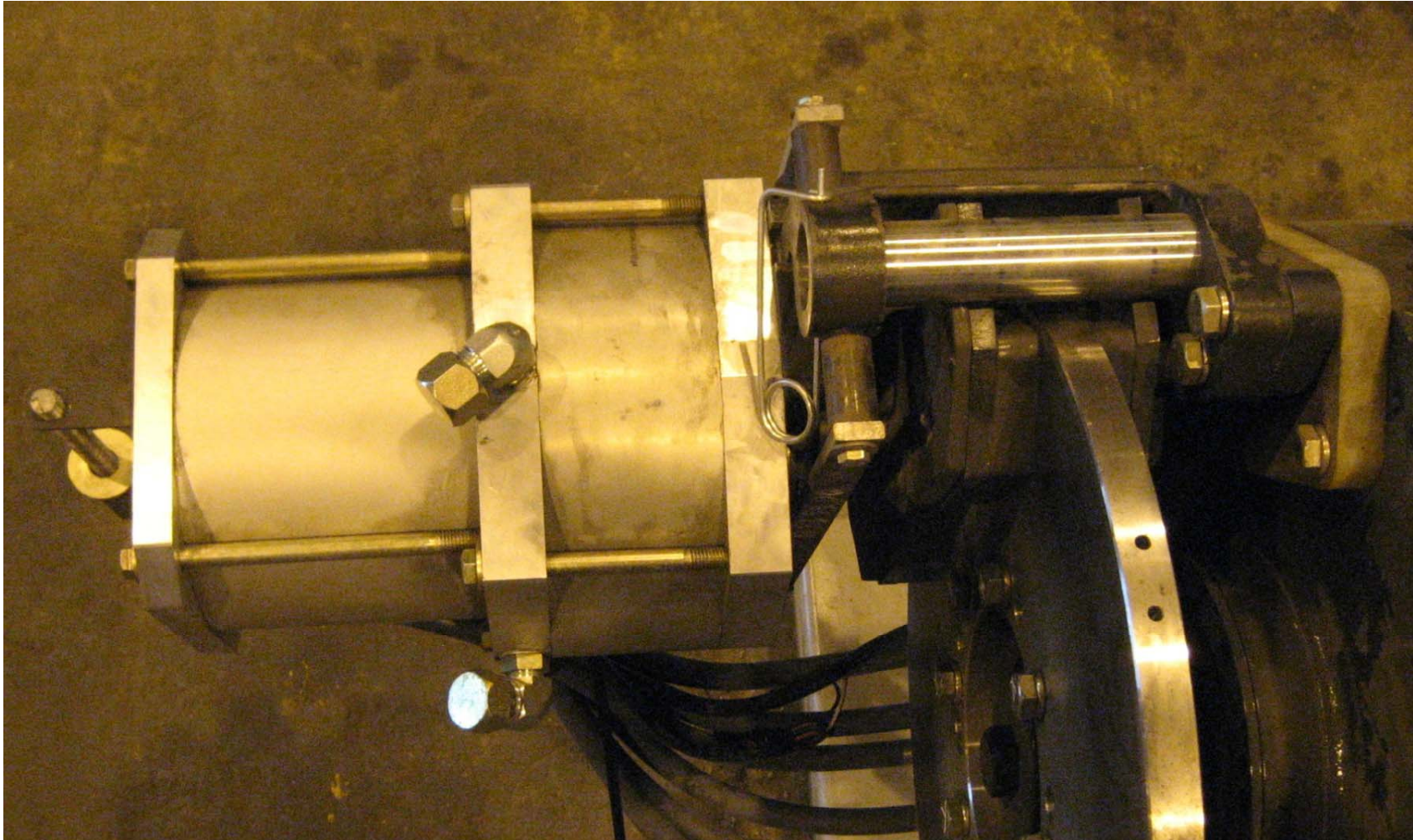

Brake Actuator

Component Descriptions

LeTourneau Technologies, Inc.

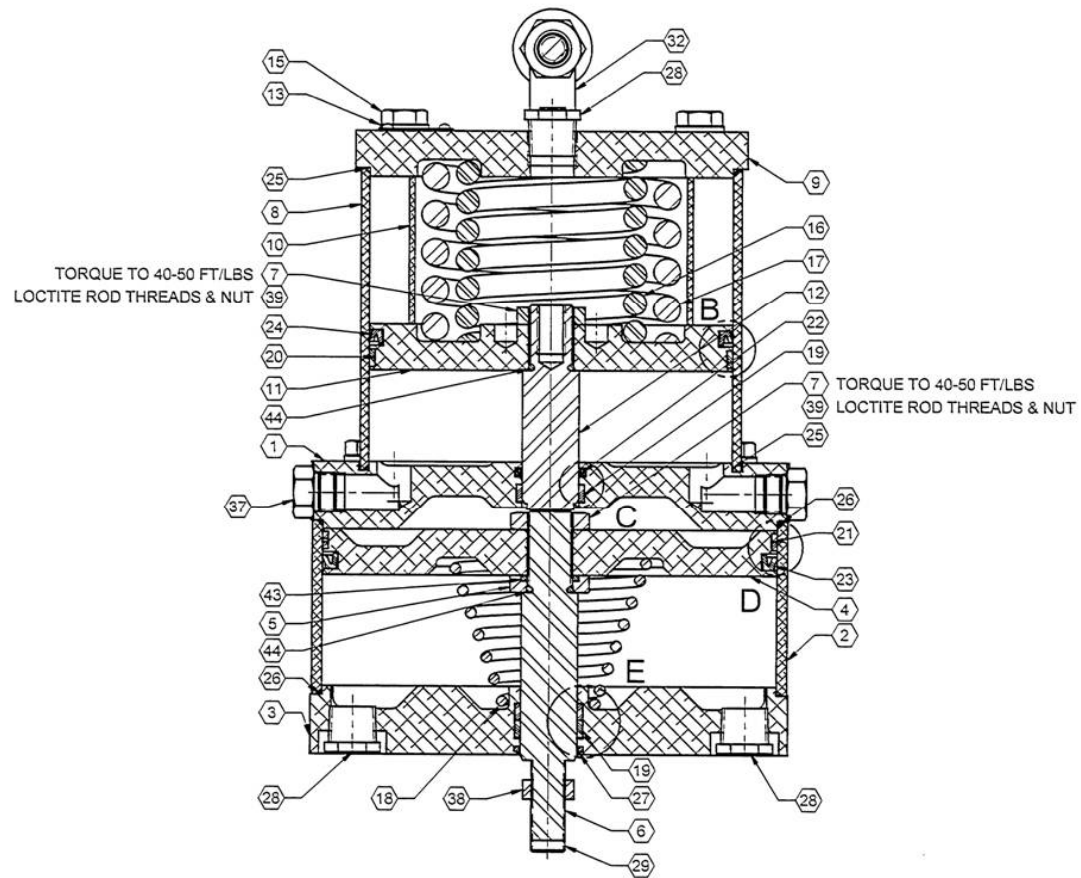

SECTION A-A

Brake Actuator



Brake Pressure Transducer

Component Descriptions

LeTourneau Technologies, Inc.

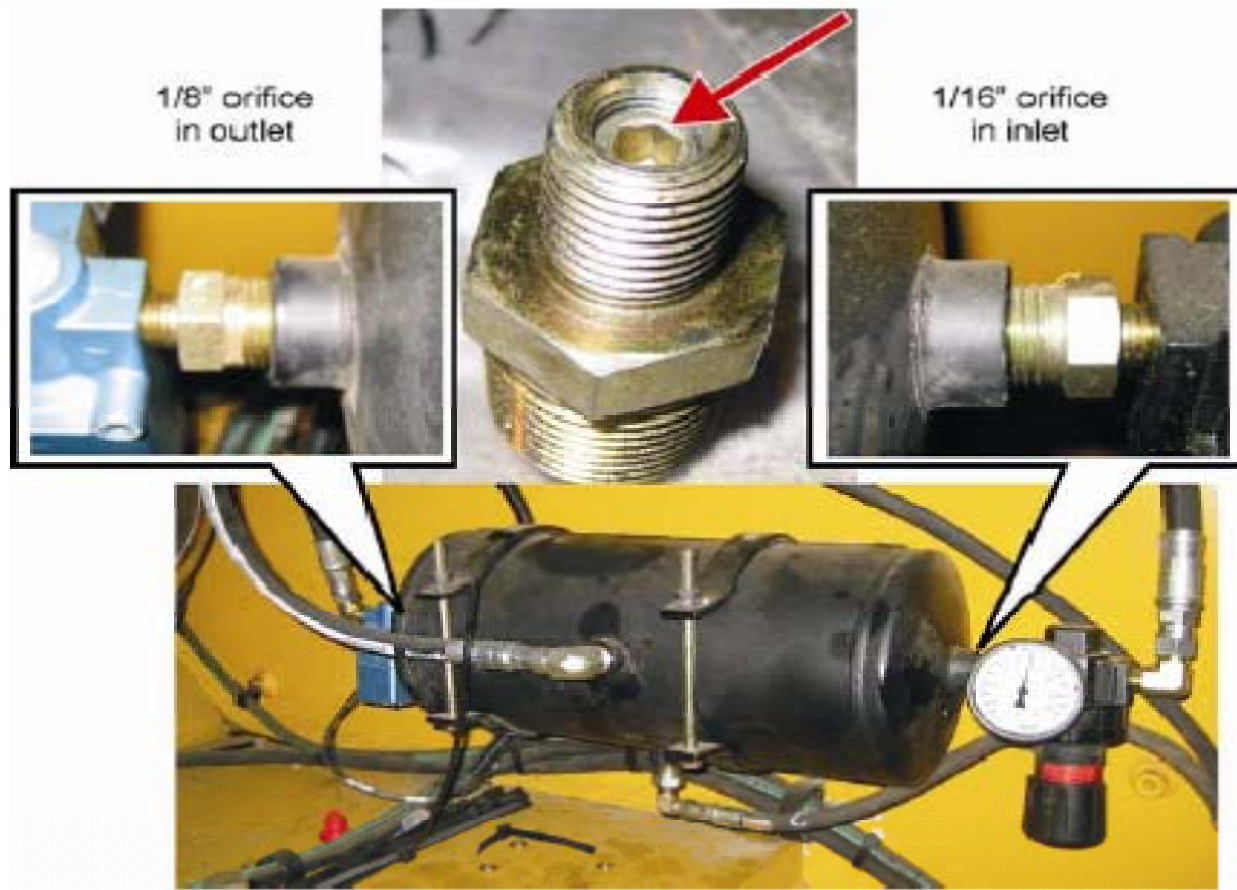

KLENZ tank orifices

KLENZ Tank

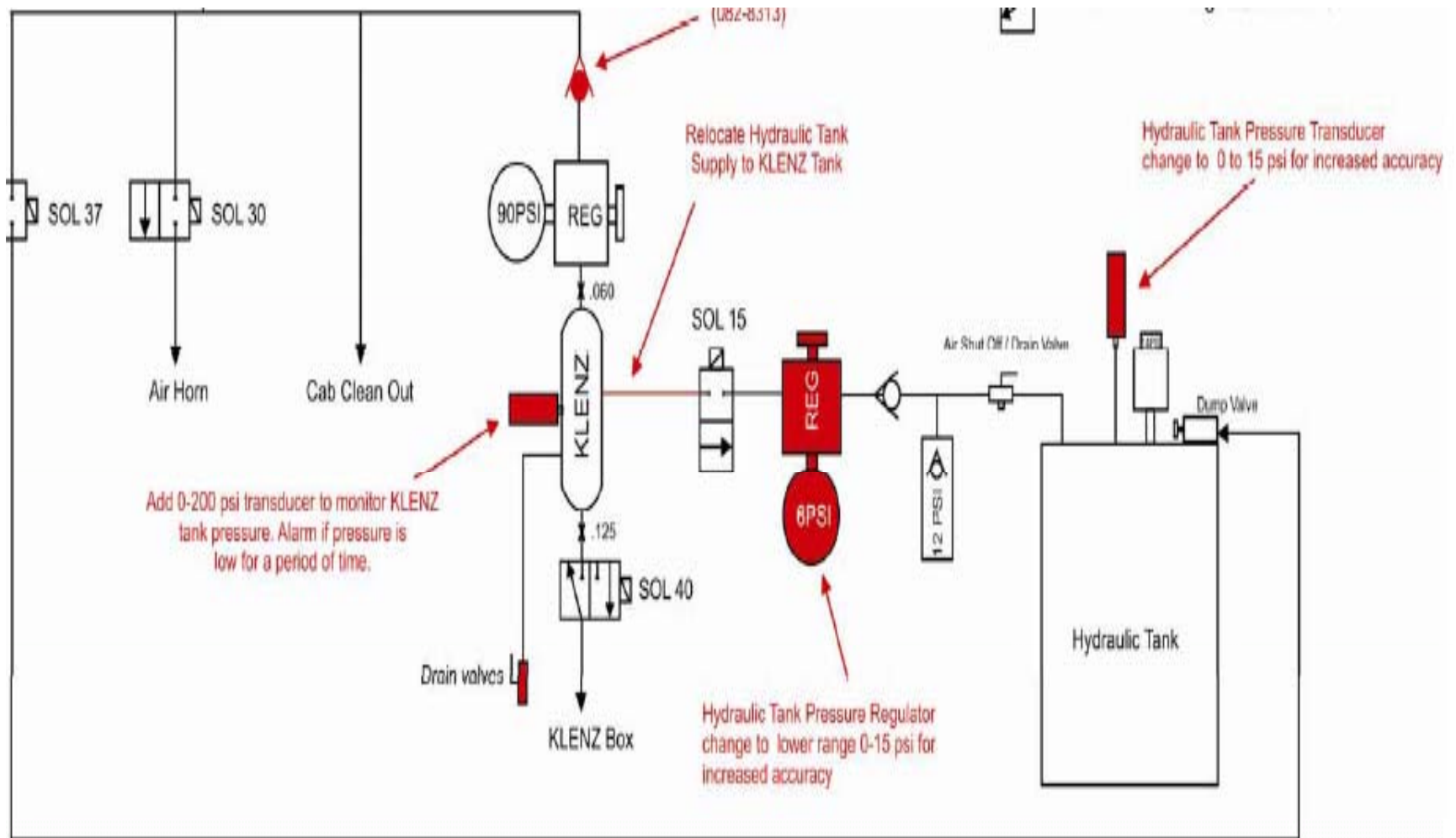

New KLENZ Components

Component Descriptions

LeTourneau Technologies, Inc.

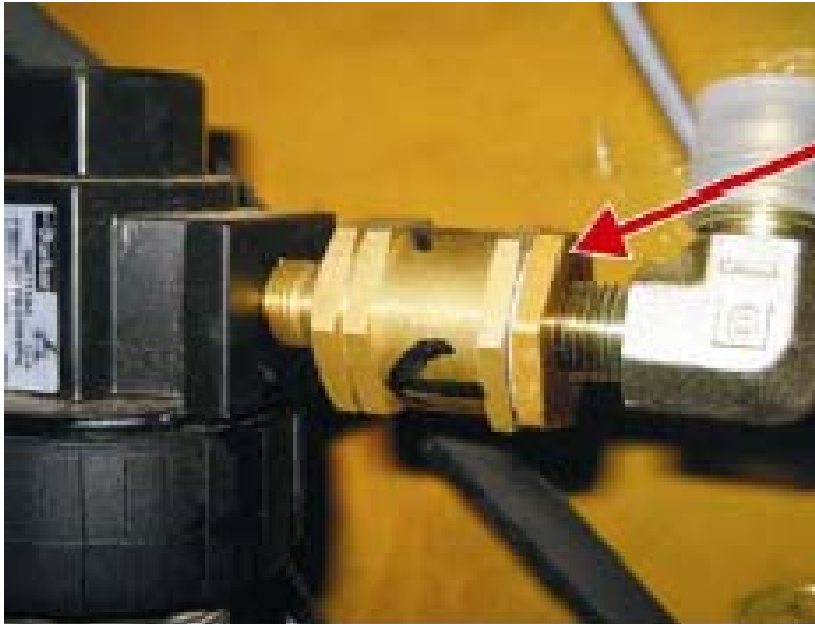

- Check inlet
- Set at 90 psi



KLENZ REGULATOR

- Solenoid 15
- 6 psi Regulator
- 12 psi Check Valve

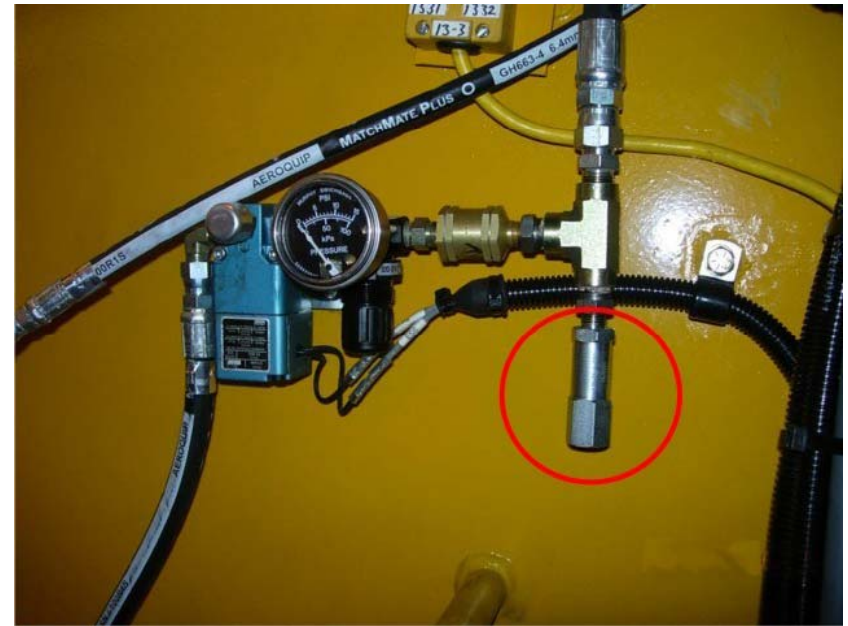

KLENZ TANK TO HYDRAULIC TANK

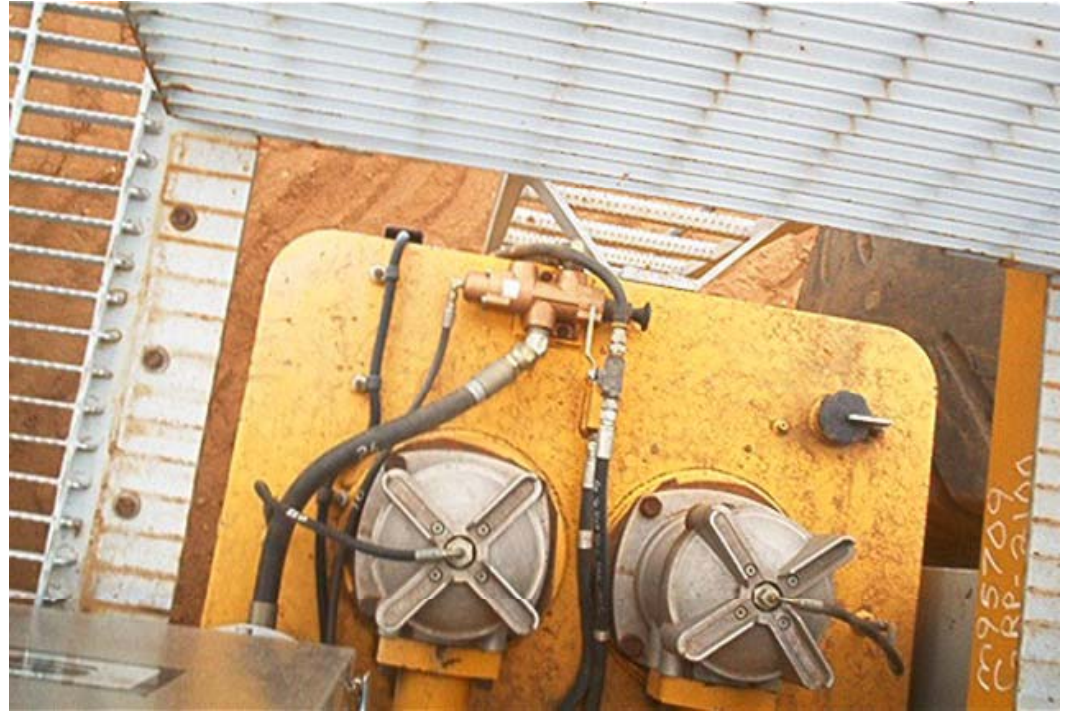

AIR SYSTEM - HYDRAULIC TANK AIR

Component Descriptions

LeTourneau Technologies, Inc.

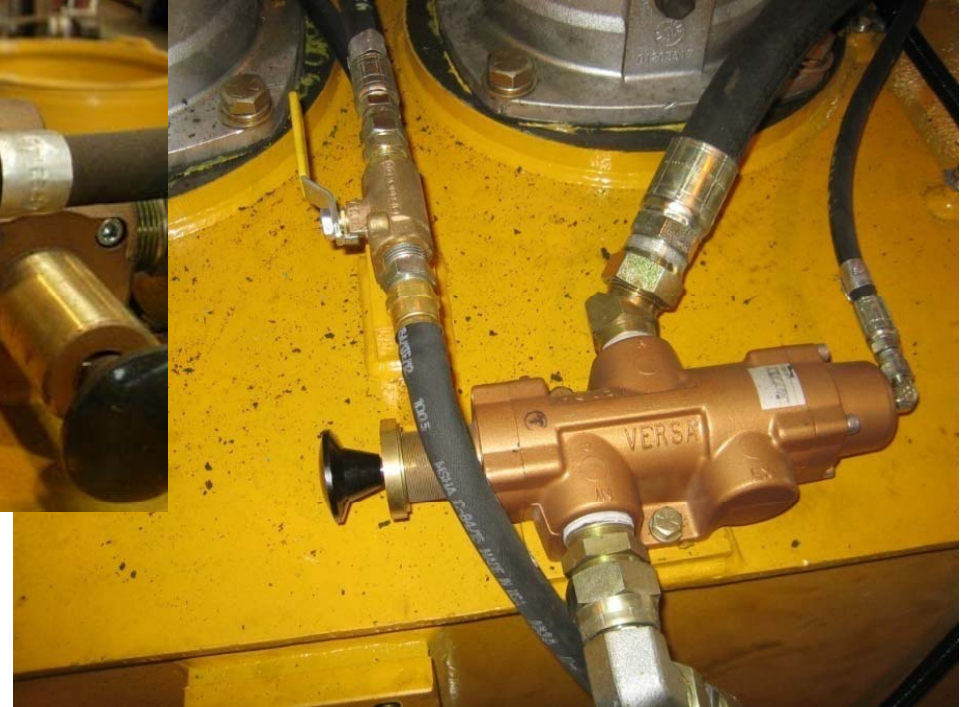

AIR SYSTEM - HYDRAULIC TANK DUMP VALVES

Component Descriptions

LeTourneau Technologies, Inc.



AIR SYSTEM HYDRAULIC SURGE TANK

Component Descriptions

LeTourneau Technologies, Inc.

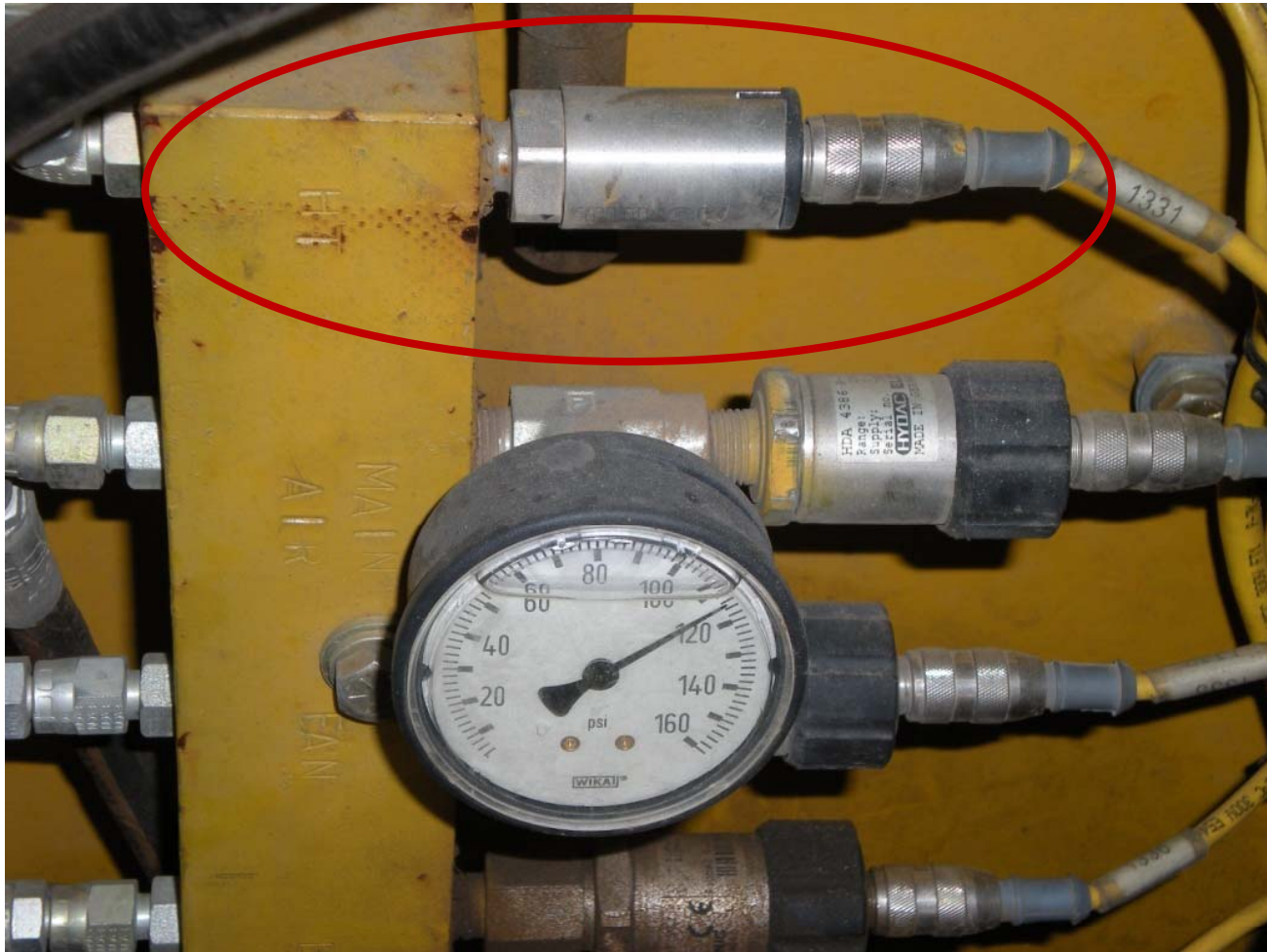

AIR SYSTEM HYDRAULIC TANK TRANSDUCER

Component Descriptions

LeTourneau Technologies, Inc.

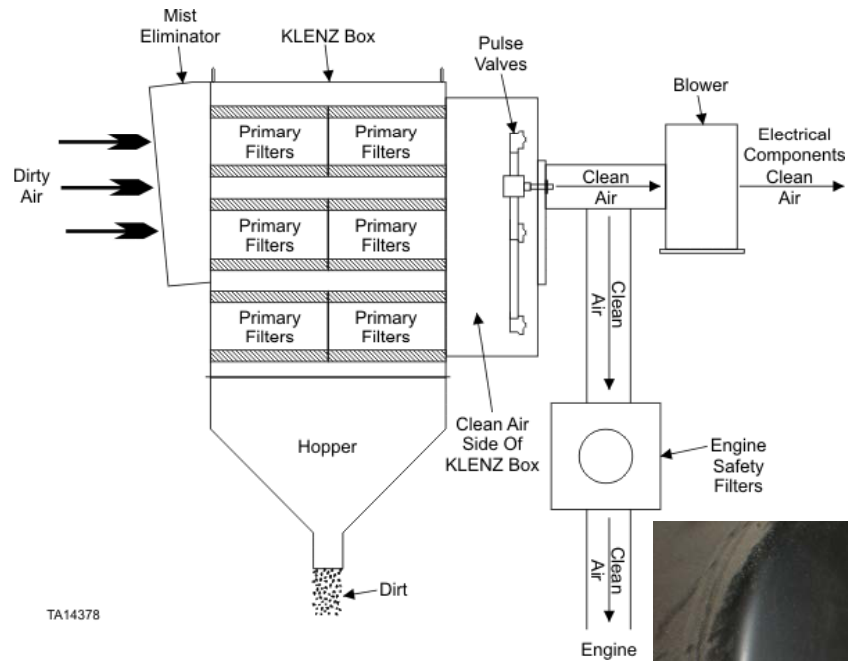

AIR SYSTEM KLENZ

Component Descriptions

LeTourneau Technologies, Inc.



Old Style

New Style



AIR SYSTEM KLENZ PULSE VALVE

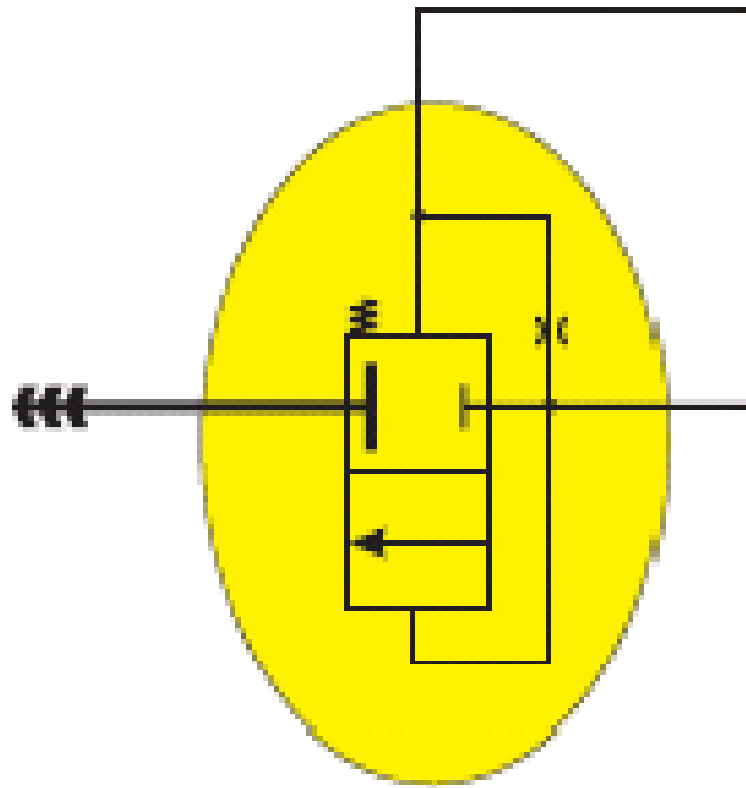

Diaphragm Valve

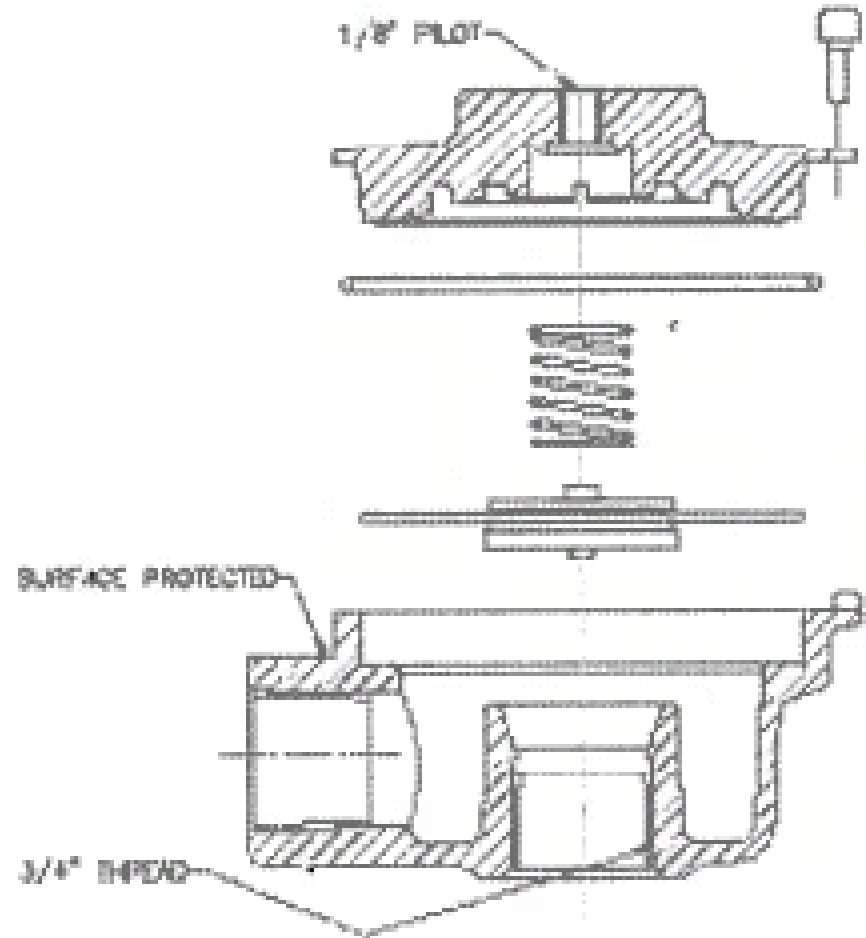

Air System Pulse Valve Operation

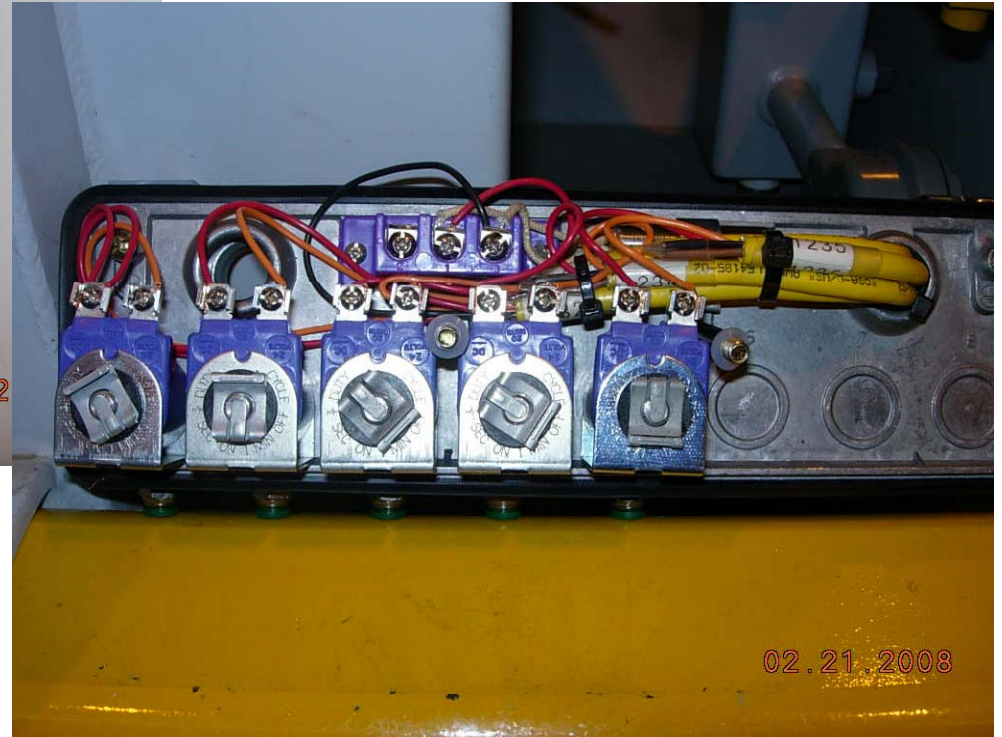

Component Descriptions

LeTourneau Technologies, Inc.

Parts

Large Style



Small Style



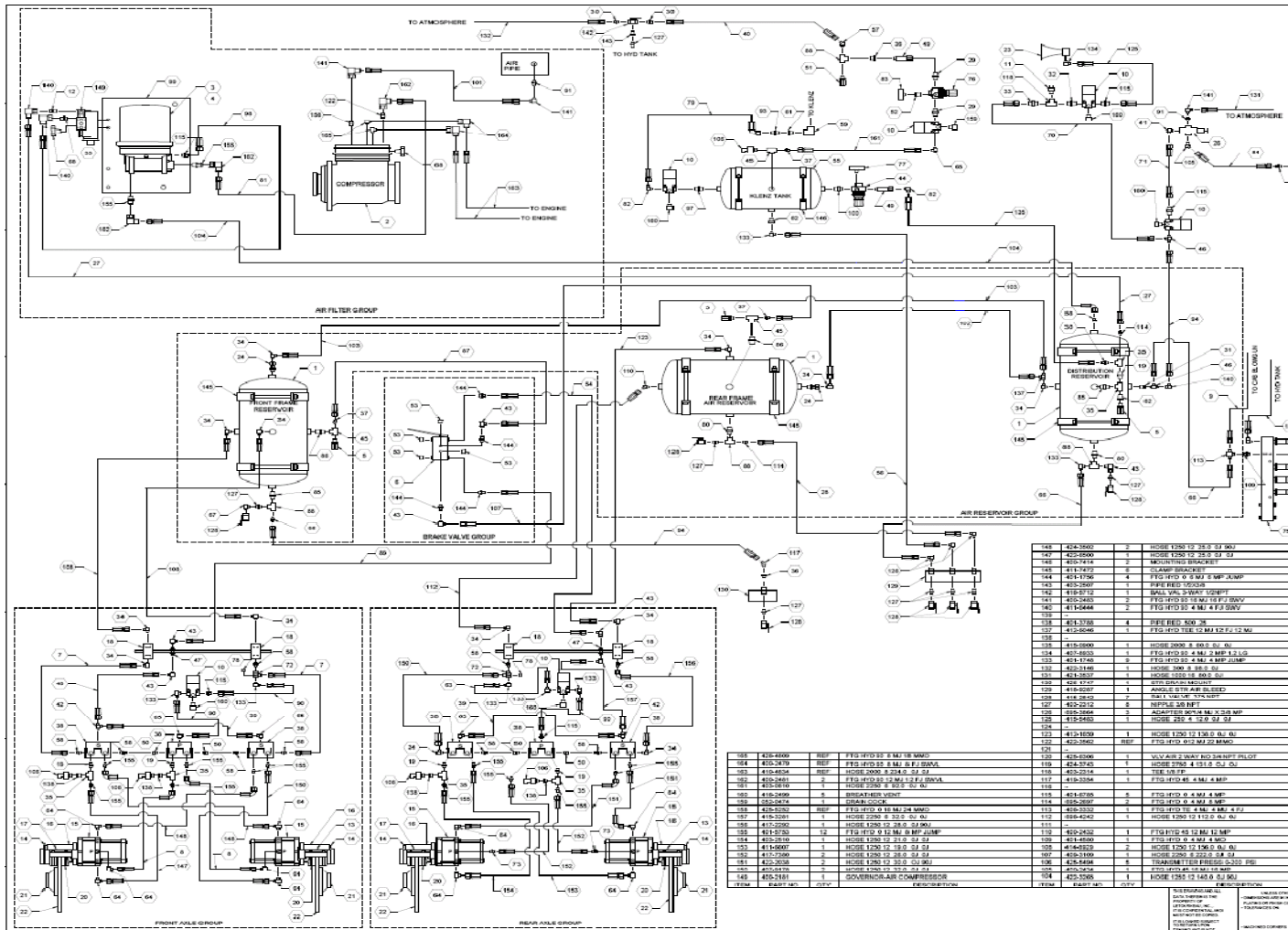

REVISED		REVISIONS		BY	DATE	CHK	APP
01	1	INITIALS	DATE				
02	1	INITIALS	DATE				
03	1	INITIALS	DATE				
04	1	INITIALS	DATE				
05	1	INITIALS	DATE				
06	1	INITIALS	DATE				
07	1	INITIALS	DATE				
08	1	INITIALS	DATE				
09	1	INITIALS	DATE				
10	1	INITIALS	DATE				
11	1	INITIALS	DATE				
12	1	INITIALS	DATE				
13	1	INITIALS	DATE				
14	1	INITIALS	DATE				
15	1	INITIALS	DATE				
16	1	INITIALS	DATE				
17	1	INITIALS	DATE				
18	1	INITIALS	DATE				
19	1	INITIALS	DATE				
20	1	INITIALS	DATE				
21	1	INITIALS	DATE				
22	1	INITIALS	DATE				
23	1	INITIALS	DATE				
24	1	INITIALS	DATE				
25	1	INITIALS	DATE				
26	1	INITIALS	DATE				
27	1	INITIALS	DATE				
28	1	INITIALS	DATE				
29	1	INITIALS	DATE				
30	1	INITIALS	DATE				
31	1	INITIALS	DATE				
32	1	INITIALS	DATE				
33	1	INITIALS	DATE				
34	1	INITIALS	DATE				
35	1	INITIALS	DATE				
36	1	INITIALS	DATE				
37	1	INITIALS	DATE				
38	1	INITIALS	DATE				
39	1	INITIALS	DATE				
40	1	INITIALS	DATE				
41	1	INITIALS	DATE				
42	1	INITIALS	DATE				
43	1	INITIALS	DATE				
44	1	INITIALS	DATE				
45	1	INITIALS	DATE				
46	1	INITIALS	DATE				
47	1	INITIALS	DATE				
48	1	INITIALS	DATE				
49	1	INITIALS	DATE				
50	1	INITIALS	DATE				
51	1	INITIALS	DATE				
52	1	INITIALS	DATE				
53	1	INITIALS	DATE				
54	1	INITIALS	DATE				
55	1	INITIALS	DATE				
56	1	INITIALS	DATE				
57	1	INITIALS	DATE				
58	1	INITIALS	DATE				
59	1	INITIALS	DATE				
60	1	INITIALS	DATE				
61	1	INITIALS	DATE				
62	1	INITIALS	DATE				
63	1	INITIALS	DATE				
64	1	INITIALS	DATE				
65	1	INITIALS	DATE				
66	1	INITIALS	DATE				
67	1	INITIALS	DATE				
68	1	INITIALS	DATE				
69	1	INITIALS	DATE				
70	1	INITIALS	DATE				
71	1	INITIALS	DATE				
72	1	INITIALS	DATE				
73	1	INITIALS	DATE				
74	1	INITIALS	DATE				
75	1	INITIALS	DATE				
76	1	INITIALS	DATE				
77	1	INITIALS	DATE				
78	1	INITIALS	DATE				
79	1	INITIALS	DATE				
80	1	INITIALS	DATE				
81	1	INITIALS	DATE				
82	1	INITIALS	DATE				
83	1	INITIALS	DATE				
84	1	INITIALS	DATE				
85	1	INITIALS	DATE				
86	1	INITIALS	DATE				
87	1	INITIALS	DATE				
88	1	INITIALS	DATE				
89	1	INITIALS	DATE				
90	1	INITIALS	DATE				
91	1	INITIALS	DATE				
92	1	INITIALS	DATE				
93	1	INITIALS	DATE				
94	1	INITIALS	DATE				
95	1	INITIALS	DATE				
96	1	INITIALS	DATE				
97	1	INITIALS	DATE				
98	1	INITIALS	DATE				
99	1	INITIALS	DATE				
100	1	INITIALS	DATE				
101	1	INITIALS	DATE				
102	1	INITIALS	DATE				
103	1	INITIALS	DATE				
104	1	INITIALS	DATE				
105	1	INITIALS	DATE				
106	1	INITIALS	DATE				
107	1	INITIALS	DATE				
108	1	INITIALS	DATE				
109	1	INITIALS	DATE				
110	1	INITIALS	DATE				
111	1	INITIALS	DATE				
112	1	INITIALS	DATE				
113	1	INITIALS	DATE				
114	1	INITIALS	DATE				
115	1	INITIALS	DATE				
116	1	INITIALS	DATE				
117	1	INITIALS	DATE				
118	1	INITIALS	DATE				
119	1	INITIALS	DATE				
120	1	INITIALS	DATE				
121	1	INITIALS	DATE				
122	1	INITIALS	DATE				
123	1	INITIALS	DATE				
124	1	INITIALS	DATE				
125	1	INITIALS	DATE				
126	1	INITIALS	DATE				
127	1	INITIALS	DATE				
128	1	INITIALS	DATE				
129	1	INITIALS	DATE				
130	1	INITIALS	DATE				
131	1	INITIALS	DATE				
132	1	INITIALS	DATE				
133	1	INITIALS	DATE				
134	1	INITIALS	DATE				
135	1	INITIALS	DATE				
136	1	INITIALS	DATE				
137	1	INITIALS	DATE				
138	1	INITIALS	DATE				
139	1	INITIALS	DATE				
140	1	INITIALS	DATE				
141	1	INITIALS	DATE				
142	1	INITIALS	DATE				
143	1	INITIALS	DATE				
144	1	INITIALS	DATE				
145	1	INITIALS	DATE				
146	1	INITIALS	DATE				
147	1	INITIALS	DATE				
148	1	INITIALS	DATE				
149	1	INITIALS	DATE				
150	1	INITIALS	DATE				
151	1	INITIALS	DATE				
152	1	INITIALS	DATE				
153	1	INITIALS	DATE				
154	1	INITIALS	DATE				
155	1	INITIALS	DATE				
156	1	INITIALS	DATE				
157	1	INITIALS	DATE				
158	1	INITIALS	DATE				
159	1	INITIALS	DATE				
160	1	INITIALS	DATE				
161	1	INITIALS	DATE				
162	1	INITIALS	DATE				
163	1	INITIALS	DATE				
164	1	INITIALS	DATE				
165	1	INITIALS	DATE				
166	1	INITIALS	DATE				
167	1	INITIALS	DATE				
168	1	INITIALS	DATE				
169	1	INITIALS	DATE				
170	1	INITIALS	DATE				
171	1	INITIALS	DATE				
172	1	INITIALS	DATE				
173	1	INITIALS	DATE				
174	1	INITIALS	DATE				
175	1	INITIALS	DATE				
176	1	INITIALS	DATE				
177	1	INITIALS	DATE				
178	1	INITIALS	DATE				
179	1	INITIALS	DATE				
180	1	INITIALS	DATE				
181	1	INITIALS	DATE				
182	1	INITIALS	DATE				
183	1	INITIALS	DATE				
184	1	INITIALS	DATE				
185	1	INITIALS	DATE				
186	1	INITIALS	DATE				
187	1	INITIALS	DATE				
188	1	INITIALS	DATE				
189	1	INITIALS	DATE				
190	1	INITIALS	DATE				
191	1	INITIALS	DATE				
192	1	INITIALS	DATE				
193	1	INITIALS	DATE				
194	1	INITIALS	DATE				
195	1	INITIALS	DATE				
196	1	INITIALS	DATE				
197	1	INITIALS	DATE				
198	1	INITIALS	DATE				
199	1	INITIALS	DATE				
200	1	INITIALS	DATE				

103	418-0005	1	HOSE 1200 12 1/4" O.D. AU				
104	418-0006	1	HOSE 1200 12 1/4" O.D. AU				
105	421-0357	1	HOSE 1000 10 4/8" O.D. 4 MP				
106	421-0358	1	HOSE 1000 10 4/8" O.D. 4 MP				
107	421-0400	1	HOSE 1000 10 4/8" O.D. 4 MP				

CIRCUIT DESCRIPTIONS



AIR SYSTEM

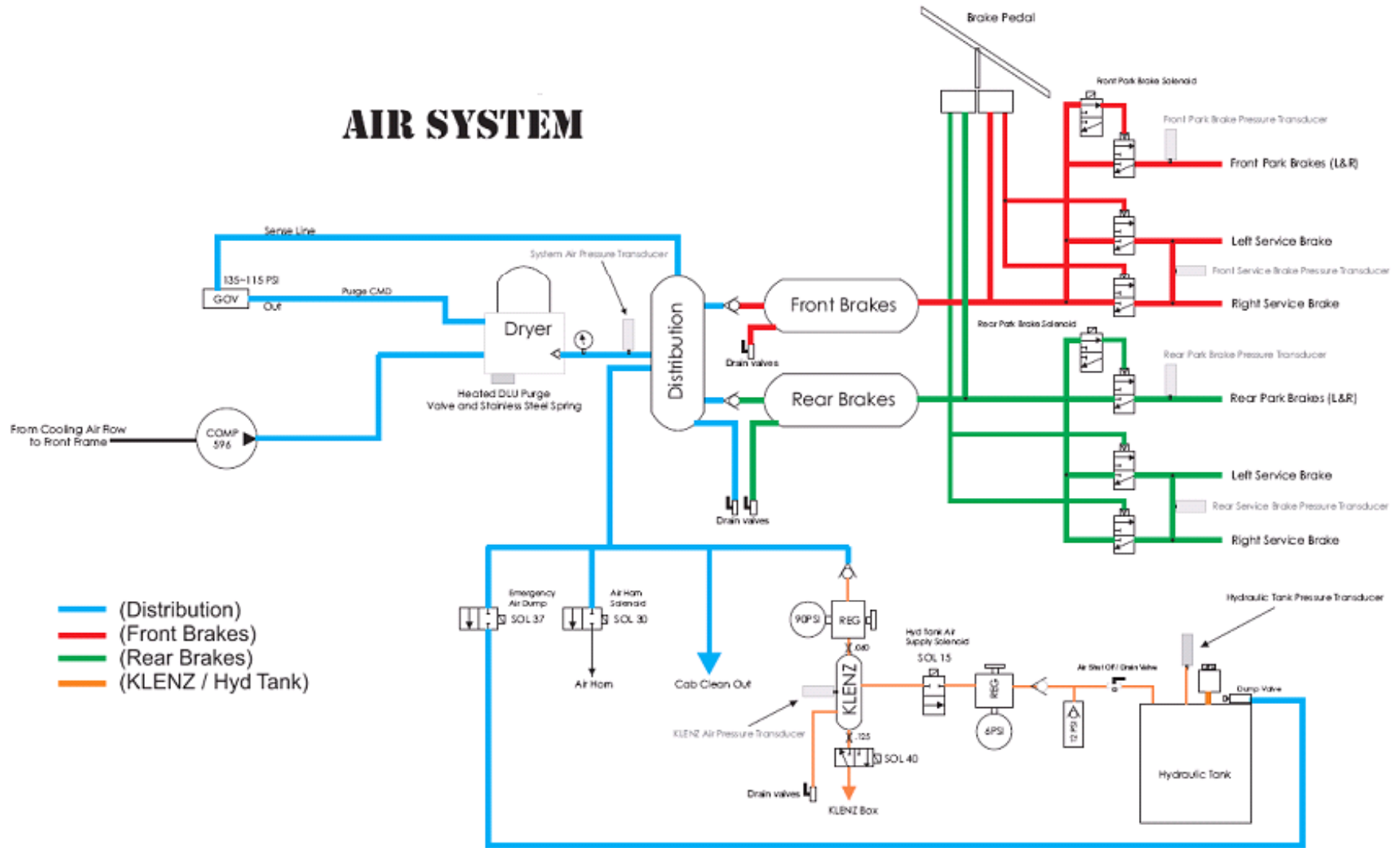

50 Series Air System

Circuit Description

LeTourneau Technologies, Inc.

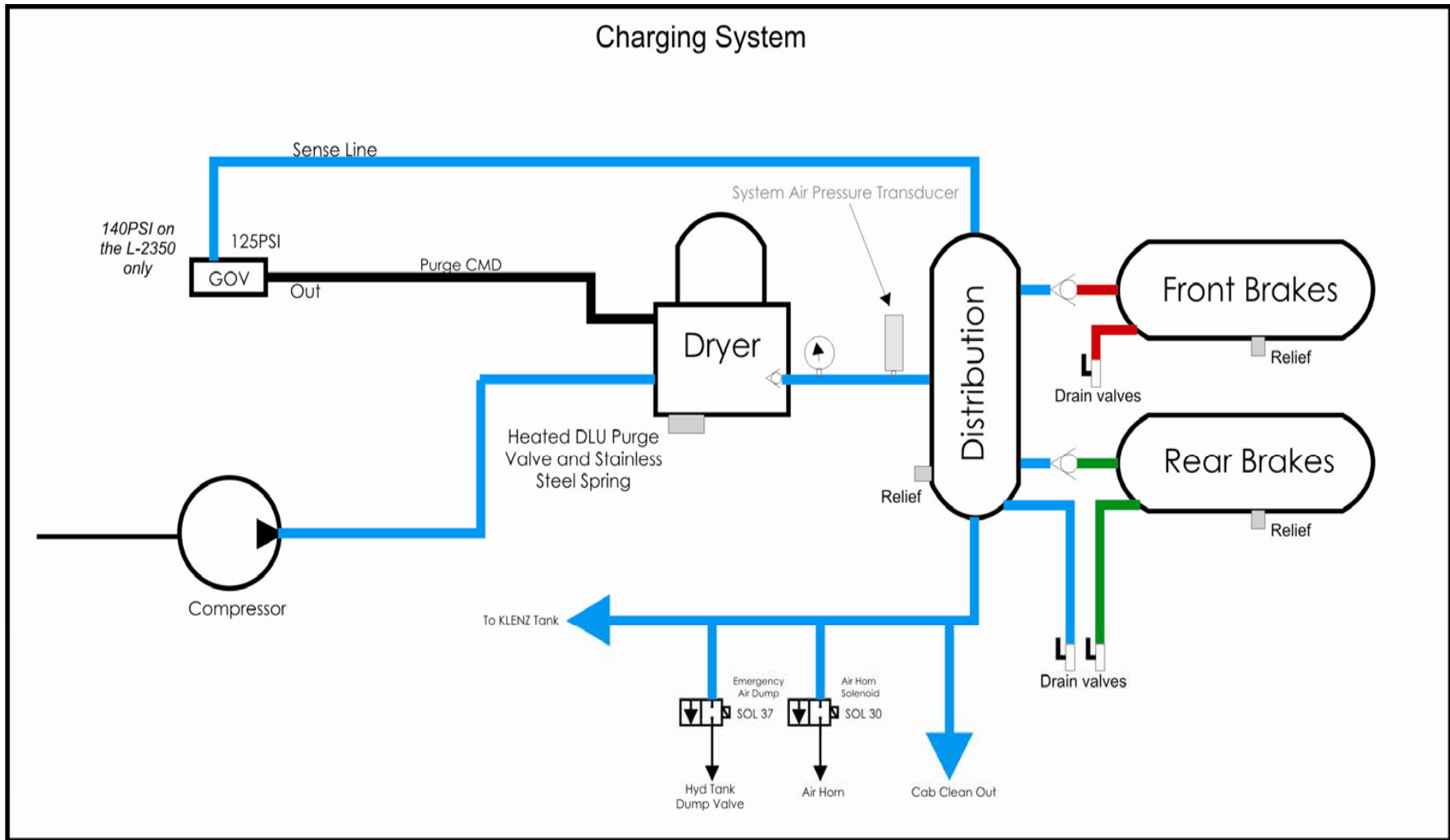

Air System Charging

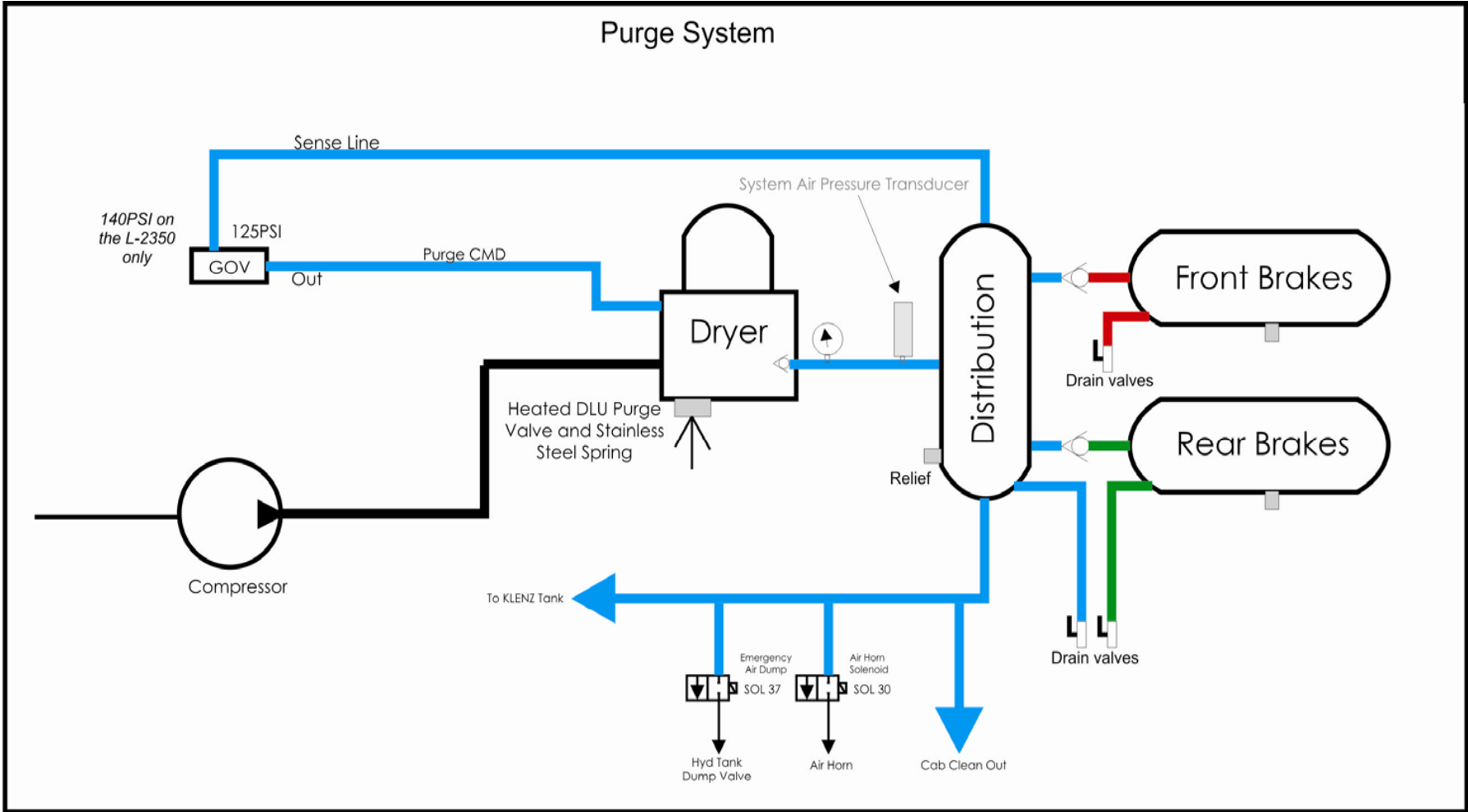

Air System Purge

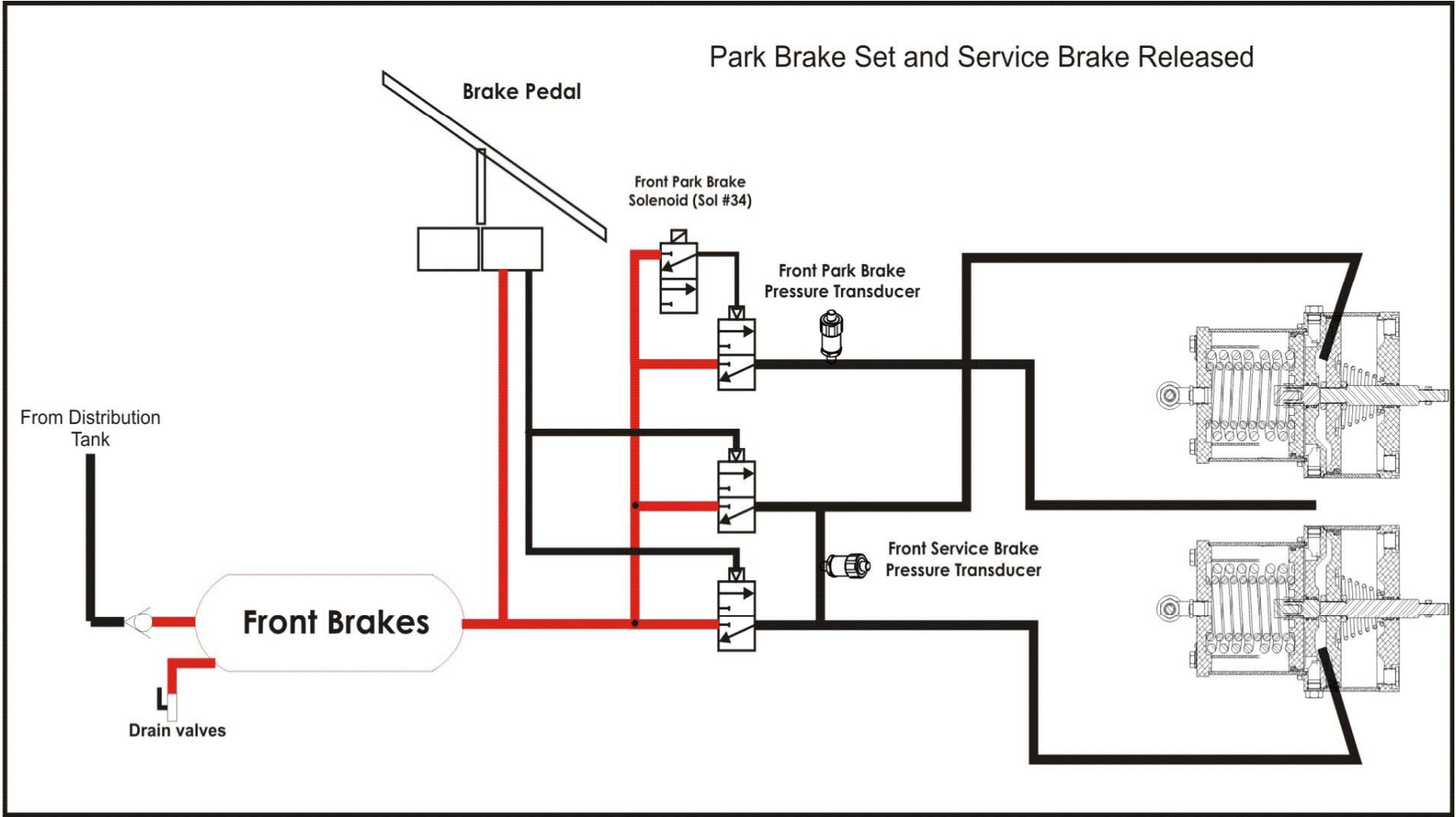

Air System Park Brake Set

Circuit Description

LeTourneau Technologies, Inc.

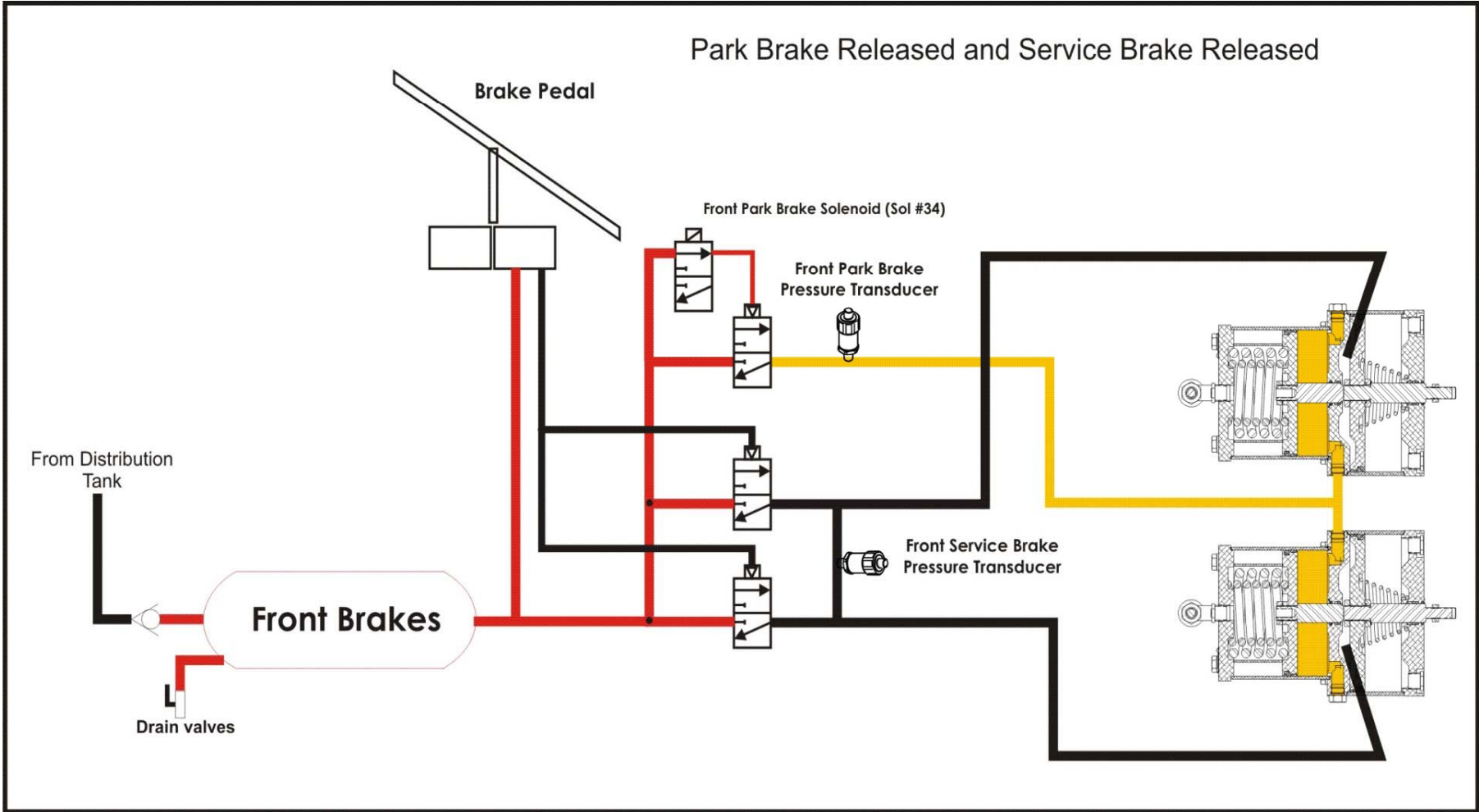

Air System Park Brake Released

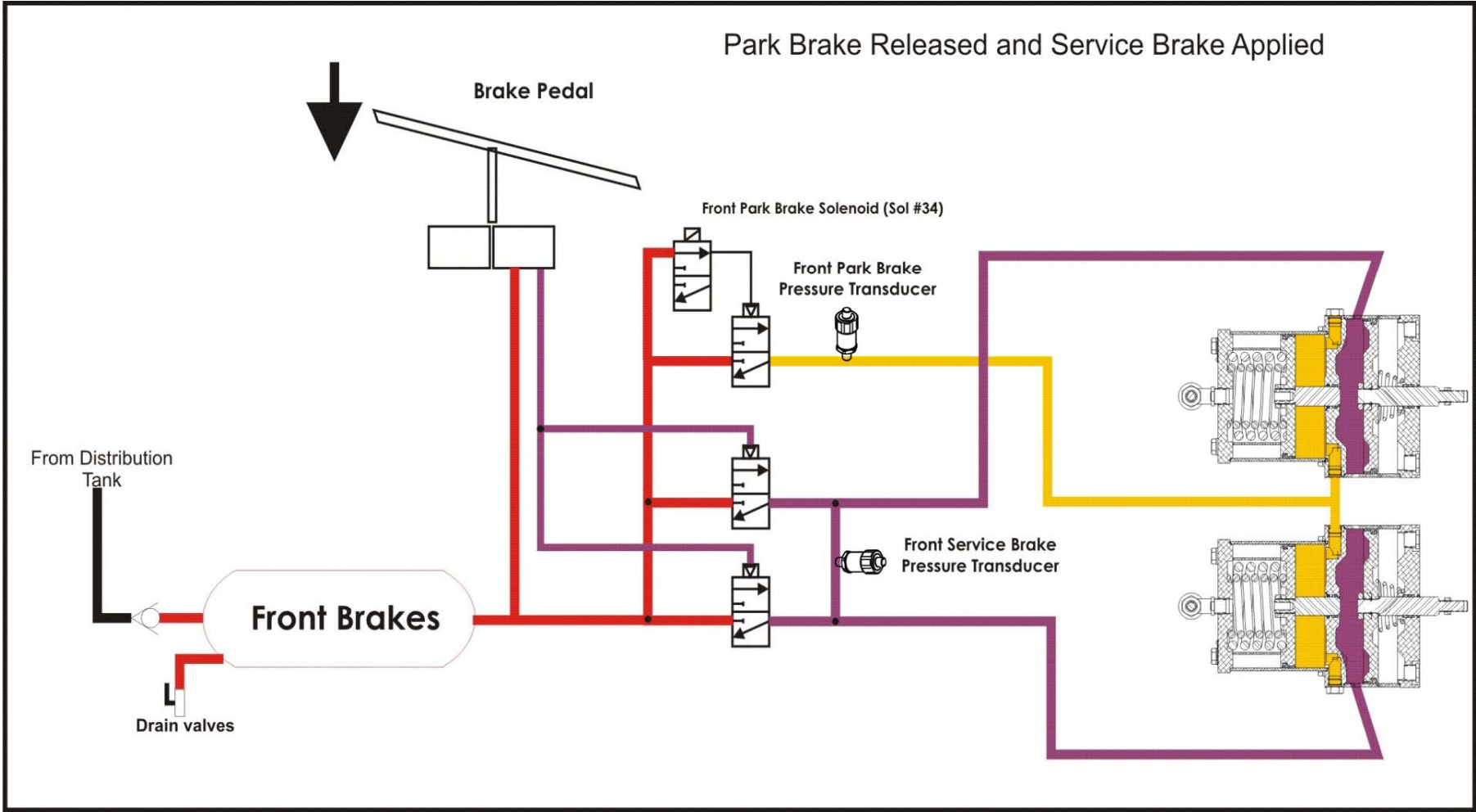

Air System Service Brake Applied

Circuit Description

LeTourneau Technologies, Inc.

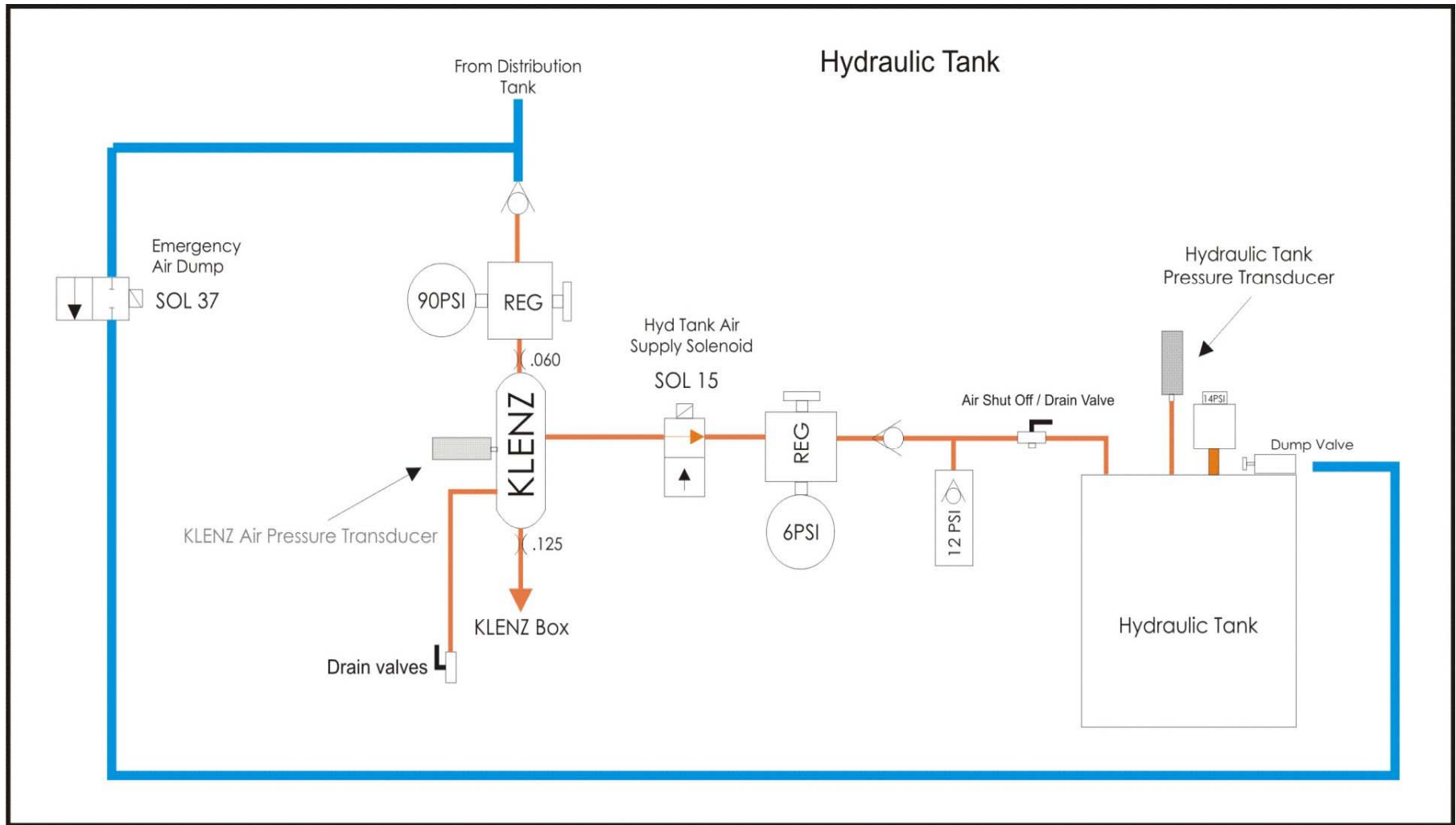

Air System Hydraulic Air Supply

Circuit Description

LeTourneau Technologies, Inc.

KLENZ Pulse Valve Circuit

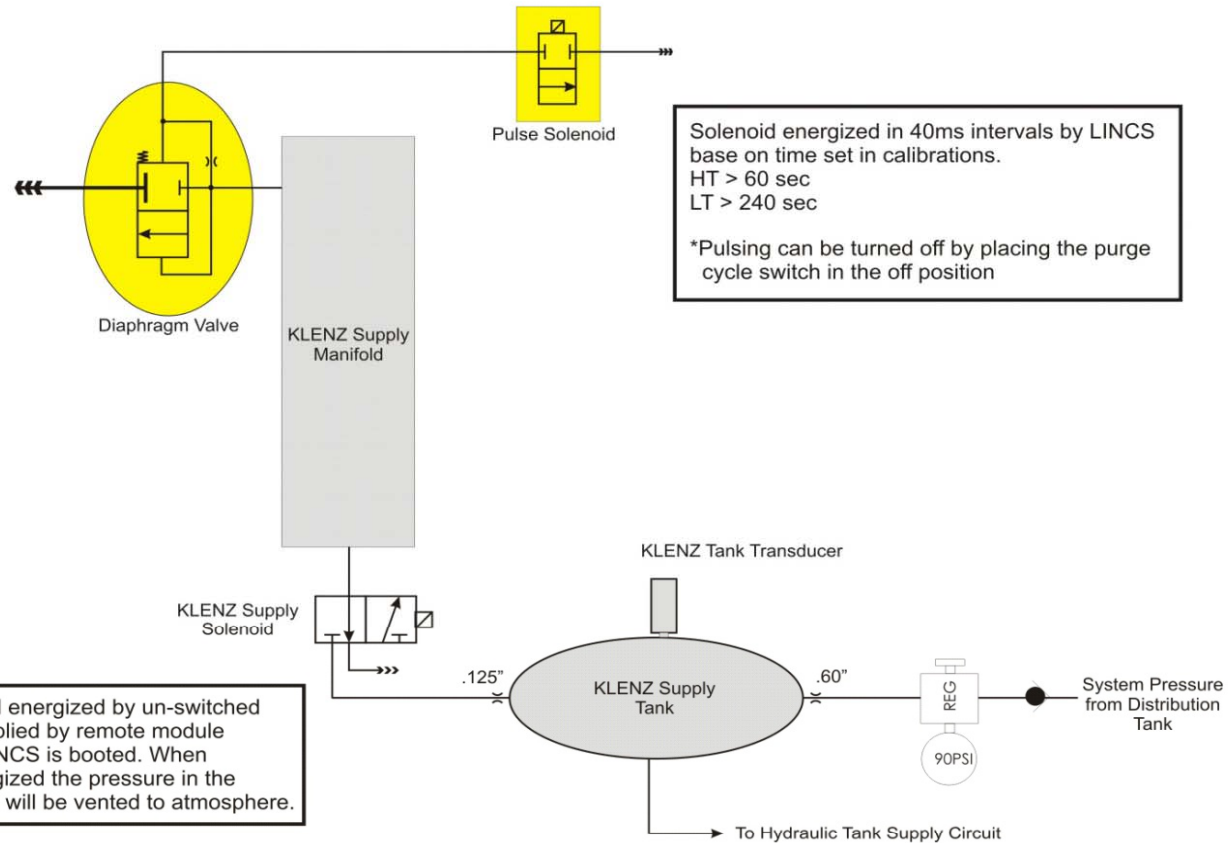

KLENZ Circuit Operation

SETTINGS AND ADJUSTMENTS



	L-950, L-1350, L-1850	L-2350
Compressor Governor	130~135 psi	140~145 psi
Hydraulic Tank	6 to 8psi	6 to 8psi
Klenz System	90 psi	90 psi



- Old style governor settings
 - L1350, L1850, and L2350 = 140 to 145 psi
 - L950 = 130 to 135 psi
- New style governor settings
 - L2350 = 140 to 145 psi
 - L1850, L1350, L1150, and L950 = 125 to 130psi
- KLENZ Tank Regulator = 90 psi
- Hydraulic Tank Regulator = 6 to 8 psi

Air System Adjustments



Adjustment of D-2 governor:

1. Remove the waterproof cap
2. Use a flat blade screwdriver to hold the adjusting screw.
3. Loosen the adjusting screw jam nut
4. To increase the pressure settings, turn the adjusting screw counter-clockwise
5. To decrease the pressure settings, turn the adjusting screw clockwise

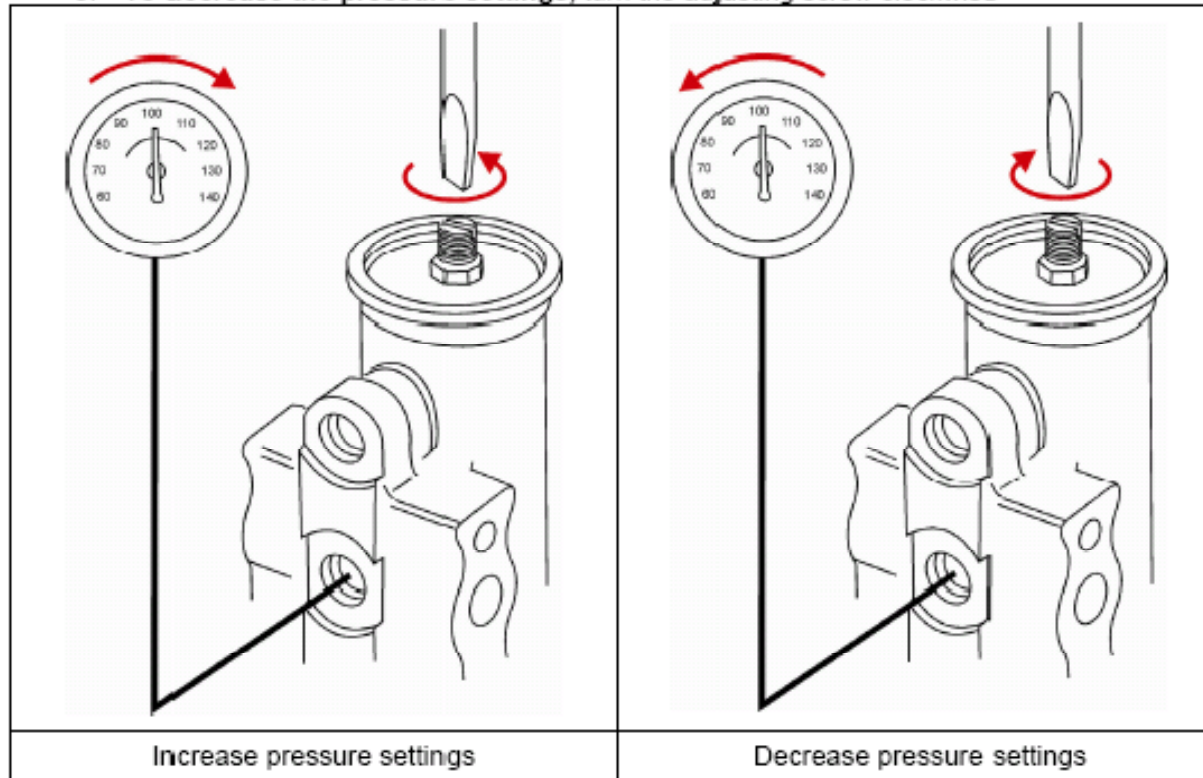

Air System Main Governor Setting



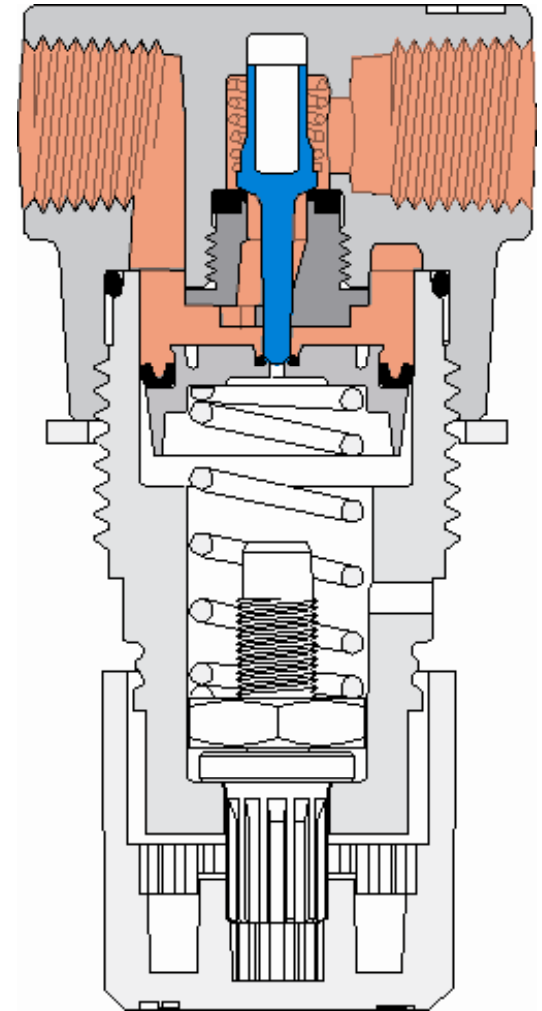

Air System Regulator Settings

Settings and Adjustments

LeTourneau Technologies, Inc.



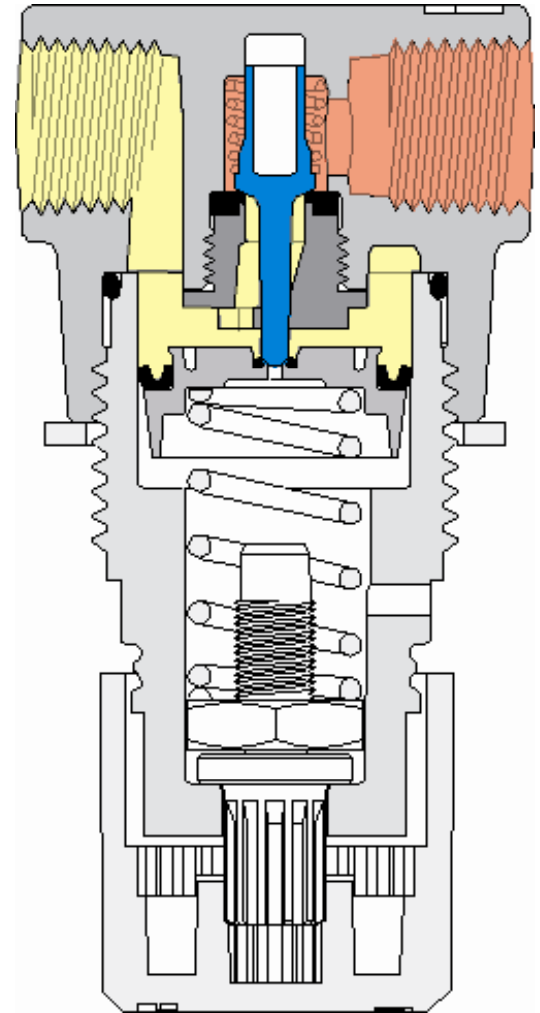

Air System Regulator Settings

Settings and Adjustments

LeTourneau Technologies, Inc.



INSTALLATION AND REMOVAL



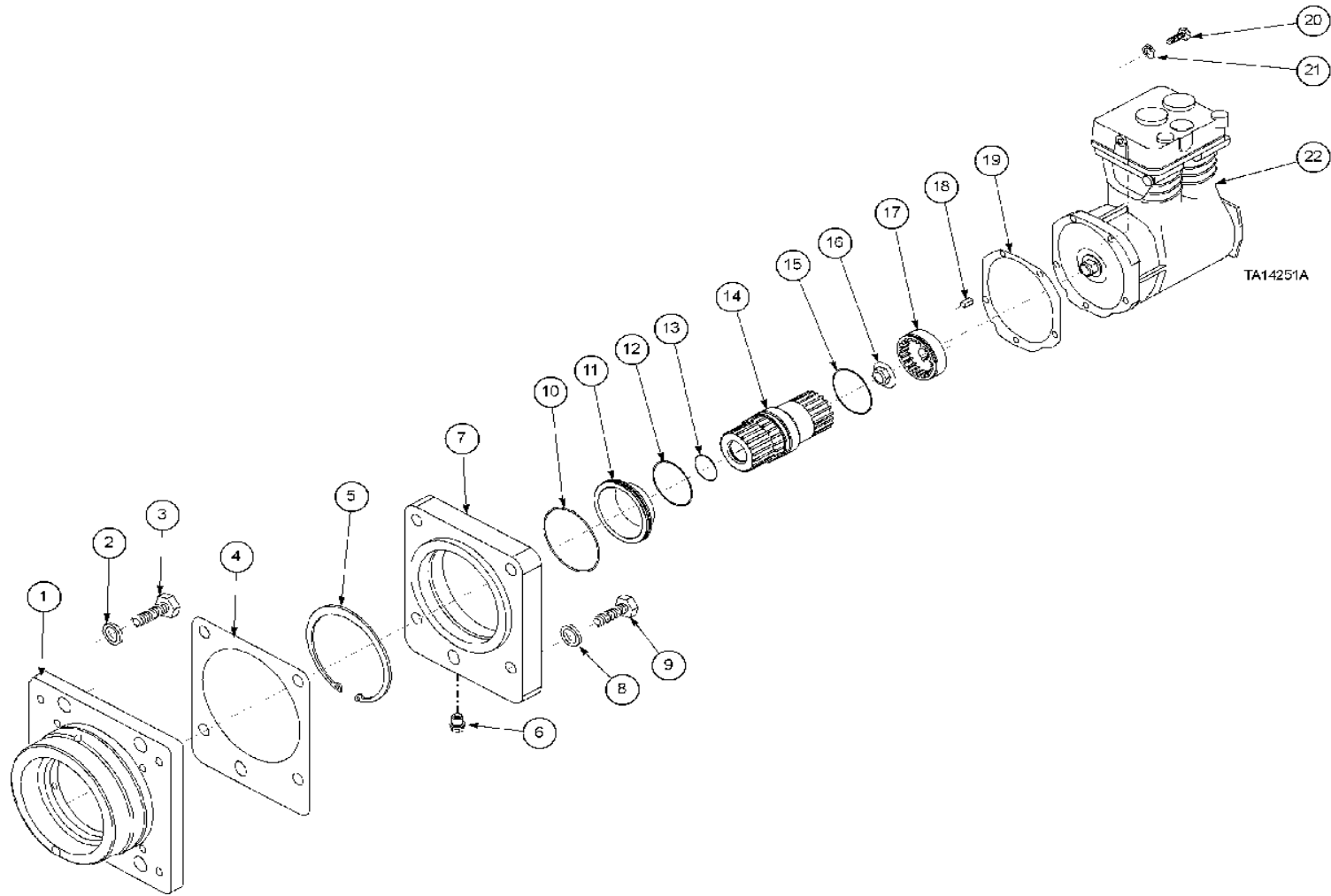

Air System Bendix 596 Break Down

Installation and Removal

LeTourneau Technologies, Inc.



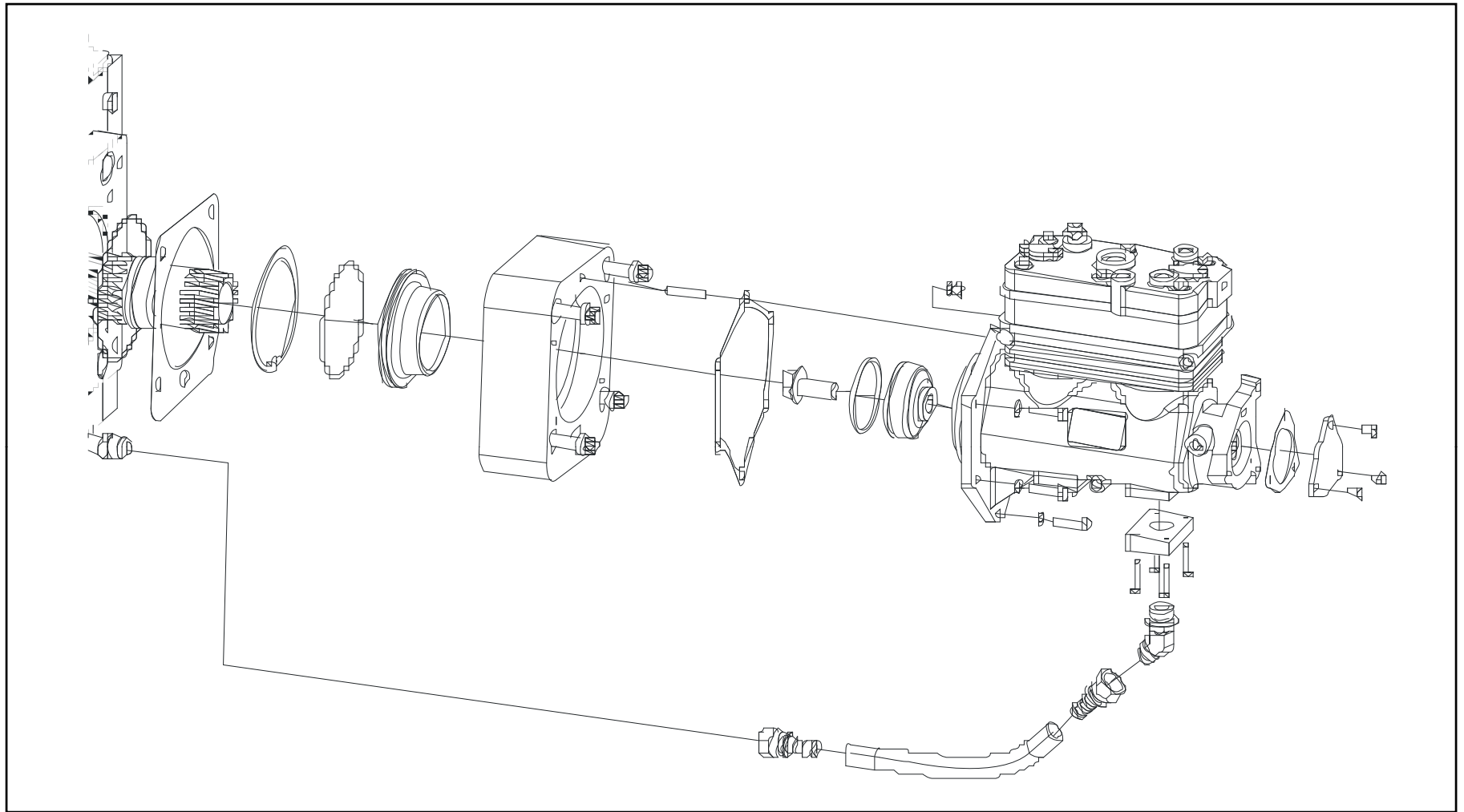

Air System Bendix 922 Break Down

Installation and Removal

LeTourneau Technologies, Inc.



TROUBLESHOOTING



50 Series Diagnostic Tool



